

PRICE 2/-

**HOW TO MAKE AND USE
SCIENTIFIC OPTICAL
INSTRUMENTS**

**CONSTRUMENTS
INSTRUCTION BOOK**
· FOR
*Optical Constructional
Outfits*

Patented in Great Britain and Abroad

COPYRIGHT BY

**CONSTRUMENTS LTD., CONSTRUMENTS HOUSE
18, GRAY'S INN ROAD ——— LONDON, W.C.1**

Telephone and Telegrams : Hol. 7507-8

Price 2/-

Construments

THE HOBBY OF TEN
THOUSAND THRILLS

Patented in Great Britain & Abroad.

How to make and use

SCIENTIFIC OPTICAL INSTRUMENTS

INSTRUCTION BOOK FOR CONSTRUMENTS OPTICAL OUTFITS

Copyright by

CONSTRUMENTS, Ltd., 18 Gray's Inn Road, London, W.C.1.

Telephone and Telegrams : Hol. 7507-8.

CONSTRUMENTS

COMPLETE SETS FOR CHEMISTRY

INCLUDING MICRO-CHEMISTRY AND
SMALL SCALE CHEMISTRY

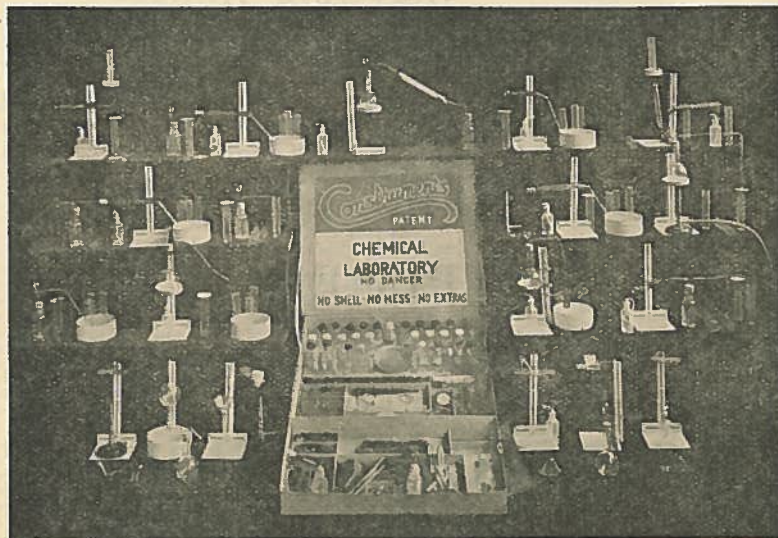

The above illustrates a few sets of apparatus which can be built up from Laboratory No. 4, as illustrated.

By the adoption of small-scale apparatus and micro-chemistry, Construments Sets introduce the latest and most modern form of chemical technique, involving as it does very low initial cost and practically nothing for upkeep.

It involves no danger, no offensive or unhealthy smells and no mess, and does away with the older methods, which were both cumbersome and extremely wasteful.

The Sets are made up with genuine laboratory apparatus with simple microscope and include a complete range of the necessary chemicals.

Complete Sets from 7/6 each.

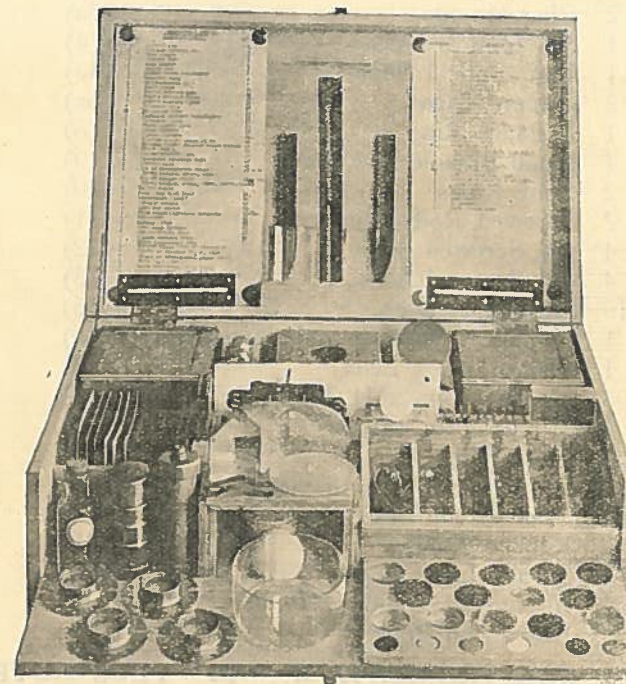

CONSTRUMENTS EDUCATIONAL SET FOR GENERAL SCIENCE AND LIGHT.

In addition to the parts contained in the "100" Set, this set contains a great number of extra parts and fittings, and will be found ideal for those who wish to go further and extend their range of action in the matter of building models and scientific instruments.

This set also contains everything necessary for a complete course in experimental optics and light, and will be found invaluable to the student, the lecturer, and the home experimenter. With it you can erect and use, amongst other things, Ray and Beam Apparatus, Spectrum Apparatus, Smoke Box, Photometers, Polariscopes, High Power Projection Apparatus, Optical Bench, etc., as well as all the models detailed in the Instruction Book.

PRICE:

IN CARDBOARD BOX - 3½ GUINEAS.

IN STOUT WOOD BOX - 4 GUINEAS.

LIST OF INSTRUMENTS IN "10" OUTFIT.

Name	No.
2 Ring Mounts	(3a)
1 3in. Optical Tube	(4)
1 1½in. Optical Tube	(4a)
2 Camera Caps	(6a)
1 Distance Ring	(8)
1 Small Pinhole Disc	(9)
2 Split Rings	(10)
2 Screwed Rods (3in.)	(11)
4 1in. Screwed Bolts	(12)
4 ½in. Screwed Bolts	(13)
15 Hexagonal Nuts	(15)
1 Combined Spanner and Screwdriver	(16)
1 Plano-Convex Lens	(18)
3 Mirrors (3in. x 11/16in.)	(19)
2 Mirrors (2in. square)	(20)
2 Glass Slides	(23)
1 Frosted Disc (1in. diameter)	(26)
1 Transparent Disc (Red)	(27)
2 Rubber Bands	(37)
1 3/16in. Lens Stop	(37a)
1 Instrument Stand	(38)
Instruction Book.	

LIST OF INSTRUMENTS IN "10" PLUS OUTFIT.

Name	No.
1 Optical Box	(1)
1 Lid for Optical Box	(2)
1 Screwed Ring Mount	(3)
1 Lampholder	(5)
2 Battery Clips	(7)
3 1in. Screwed Bolts	(12)
6 Terminal Nuts	(14)
1 Bi-Convex Lens	(17)
1 Glass Plate (3¼in. square)	(21)
1 Frosted Glass Plate (3¼in. square)	(22)
1 Focus Electric Bulb	(24)
1 Bi-Convex Electric Bulb	(25)
1 Blue Transparent Disc	(28)
1 Green Transparent Disc	(29)
1 Yellow Transparent Disc	(30)
1 Red Opaque Disc	(31)
1 Yellow Opaque Disc	(32)
1 Green Opaque Disc	(33)
1 Blue Opaque Disc	(34)
1 White Opaque Disc	(35)
1 Black Opaque Disc	(36)

LIST OF INSTRUMENTS IN "20" OUTFIT.

Name	No.
1 Optical Box	(1)
1 Lid for Optical Box	(2)
1 Screwed Ring Mount	(3)
1 Plain Ring Mount	(3a)
1 Optical Tube (3in.)	(4)
1 Optical Tube (1½in.)	(4a)
1 Lampholder	(5)
1 Camera Cap	(6)
1 Camera Cap	(6a)
2 Battery Clips	(7)
1 Distance Ring	(8)
1 Small Pinhole Disc (1in. diam.)	(9)
2 Split Rings	(10)
2 3in. Screwed Rods	(11)
7 1in. Screwed Bolts	(12)
4 ½in. Screwed Bolts	(13)
6 Terminal Nuts	(14)
15 Hexagonal Nuts	(15)
1 Combined Spanner and Screwdriver	(16)
1 Bi-Convex Lens	(17)
1 Plano-Convex Lens	(18)
3 Mirrors (3in. x 11/16in.)	(19)
2 Mirrors (2in. square)	(20)
1 Glass Plate (3¼in. square)	(21)
1 Frosted Glass Plate (3¼in. square)	(22)
2 Glass Slides (3in. x 1in.)	(23)
1 Focus Electric Bulb	(24)
1 Bi-Convex Electric Bulb	(25)
1 Frosted Disc (1in. diam.)	(26)
1 Red Transparent Disc (1in. diam.)	(27)
1 Yellow Transparent Disc (1in. diam.)	(28)
1 Green Transparent Disc (1in. diam.)	(29)
1 Blue Transparent Disc (1in. diam.)	(30)
1 Red Opaque Disc	(31)
1 Yellow Opaque Disc	(32)
1 Green Opaque Disc	(33)
1 Blue Opaque Disc	(34)
1 White Opaque Disc	(35)
1 Black Opaque Disc	(36)
2 Rubber Bands	(37)
1 3/16in. Lens Stop	(37a)
Instruction Book.	

LIST OF INSTRUMENTS IN "20" PLUS OUTFIT.

Name	No.
i Screwed Ring Mount	(3)
1 Plain Ring Mount	(3a)
1 Split Ring	(10)
6 Hexagonal Nuts	(15)
2 Plano-Convex Lenses	(18)
4 Glass Slides (3in. x 1in.)	(23)
4 Rubber Bands	(37)
1 Instrument Stand	(38)
2 Tubular Mounts	(39)
2 Caps for Tubular Mounts	(40)
1 High Power Objective	(41)
1 Mount for High Power Objective	(41a)
1 Reflector	(42)
2 Spring Clips	(43)
1 Lens Stop ($\frac{1}{2}$ in.)	(44)
1 Large Pinhole Disc	(45)
2 2in. Screwed Bolts	(46)
1 Glass Collecting Tube	(47)

LIST OF INSTRUMENTS IN "100" OUTFIT.

Name	No.
1 Optical Box	(1)
1 Lid for Optical Box	(2)
2 Screwed Ring Mounts	(3)
2 Plain Ring Mounts	(3a)
1 Optical Tube (3in.)	(4)
1 Optical Tube ($1\frac{1}{2}$ in.)	(4a)
1 Lampholder	(5)
1 Camera Cap	(6)
1 Camera Cap	(6a)
2 Battery Clips	(7)
1 Distance Ring	(8)
1 Small Pinhole Disc (1in. diam.)	(9)
3 Split Rings	(10)
2 3in. Screwed Rods	(11)
7 1in. Screwed Bolts	(12)
4 $\frac{1}{2}$ in. Screwed Bolts	(13)
6 Terminal Nuts	(14)
21 Hexagonal Nuts	(15)
1 Combined Spanner and Screwdriver	(16)
1 Bi-Convex Lens	(17)
3 Plano-Convex Lenses	(18)
3 Mirrors (3in. x $11/16$ in.)	(19)

LIST OF INSTRUMENTS IN "100" OUTFIT.—Continued.

2 Mirrors (2in. square)	(20)
1 Glass Plate ($3\frac{1}{4}$ in. square)	(21)
1 Frosted Glass Plate ($3\frac{1}{4}$ in. square)	(22)
6 Glass Slides (3in. x 1in.)	(23)
1 Focus Electric Bulb	(24)
1 Bi-Convex Electric Bulb	(25)
1 Frosted Disc (1in. diam.)	(26)
1 Red Transparent Disc (1in. diam.)	(27)
1 Yellow Transparent Disc (1in. diam.)	(28)
1 Green Transparent Disc (1in. diam.)	(29)
1 Blue Transparent Disc (1in. diam.)	(30)
1 Red Opaque Disc ($5/8$ in. diam.)	(31)
1 Yellow Opaque Disc ($5/8$ in. diam.)	(32)
1 Green Opaque Disc ($5/8$ in. diam.)	(33)
1 Blue Opaque Disc ($5/8$ in. diam.)	(34)
1 White Opaque Disc ($5/8$ in. diam.)	(35)
1 Black Opaque Disc ($5/8$ in. diam.)	(36)
6 Rubber Bands	(37)
1 Lens Stop ($3/16$ in.)	(37a)
1 Instrument Stand	(38)
2 Tubular Mounts	(39)
2 Caps for Tubular Mounts	(40)
1 High Power Objective	(41)
1 Mount for High Power Objective	(41a)
1 Reflector	(42)
2 Spring Clips	(43)
1 Lens Stop ($\frac{1}{2}$ in.)	(44)
1 Large Pinhole Disc (1in. diam.)	(45)
2 Screwed Bolts (2in.)	(46)
1 Glass Collecting Tube	(47)

NOTE.—The "20" and "20" Plus Outfits form the "100" Outfit.

PRICE LIST OF INSTRUMENTS.

Name	No.	Price s. d.
Battery Clip	(7)	4
Camera Cap	(6)	6
Camera Cap	(6a)	6
Cap for Tubular Mount	(40)	6
Disc (Transparent 1in. diam. Red, Yellow, Green, Blue)	(27)-(30)	3 per set.
Discs (Opaque $5/8$ in. diam., Red, Yellow, Green, Blue, White, Black)	(31)-(36)	$2\frac{1}{2}$ per set.
Distance Ring	(8)	2

PRICE LIST OF INSTRUMENTS.—Continued

Name	No.	Price	
		s.	d.
Dry Battery (3½ volt)		1	0
Focus Electric Bulb	(24)		6
Bi-Convex Electric Bulb	(25)		9
Frosted Glass Plate (3¼in. square)	(22)		6
Frosted Disc (1in. diam.)	(26)		1
Glass Plate (3¼in. square)	(21)		2
Glass Slide (3in. x. 1in.)	(23)		1
Glass Connecting Tube	(47)		1
Hexagonal Nut	(15)		¼
High Power Objective	(41)	2	6
High Power Objective (Improved)	(48)	5	0
Instrument Stand	(38)	2	0
Bi-Convex Lens	(17)	2	0
Plano-Convex Lens	(18)	2	6
Lens Stop (¼in.)	(44)		3
Lens Stop (3/16in.)	(37a)		3
Lid for Optical Box	(2)	1	0
Lampholder	(5)	1	3
Mirror (3in. x 11/16in)	(19)		2
Mirror (2in. x 2in.)	(20)		3
Mount for High Power Objective	(41a)	1	0
Mount for Improved High Power Objective	(48a)	1	6
Optical Box	(1)	3	0
Optical Tube (3in.)	(4)	1	0
Optical Tube (1½in.)	(4a)		6
Pinhole Disc (Small)	(9)		6
Pinhole Disc (Large)	(45)		6
Reflector	(42)	1	6
Ring Mount (Screwed)	(3)	2	0
Ring Mount (Plain)	(3a)	1	0
Rubber Band	(37)		¼
½in. Screwed Bolt	(13)		½
1in. Screwed Bolt	(12)		½
2in. Screwed Bolt	(46)		1
3in. Screwed Rod	(11)		3
Spanner and Screwdriver	(16)		3
Spring Clip	(43)		1
Split Ring	(10)		1
Terminal Nut	(14)		½
Tubular Mount	(39)	1	6

HOW TO IDENTIFY INSTRUMENTS. 9

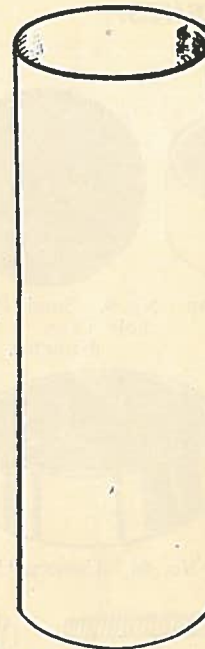

No. 4. Optical Tube.

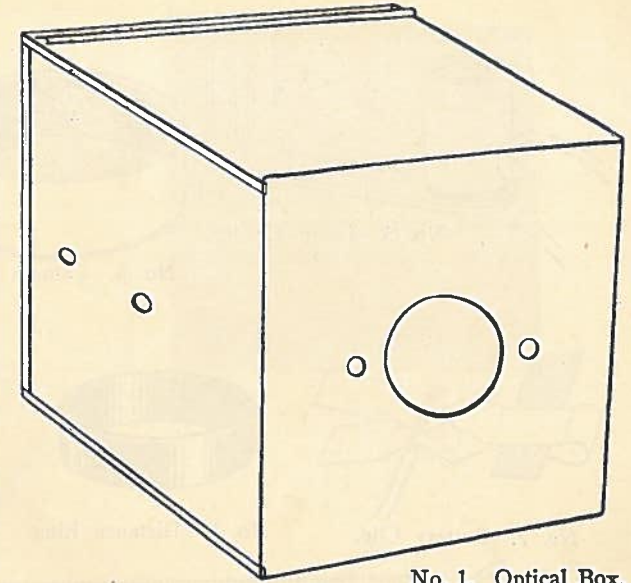

No. 1. Optical Box.

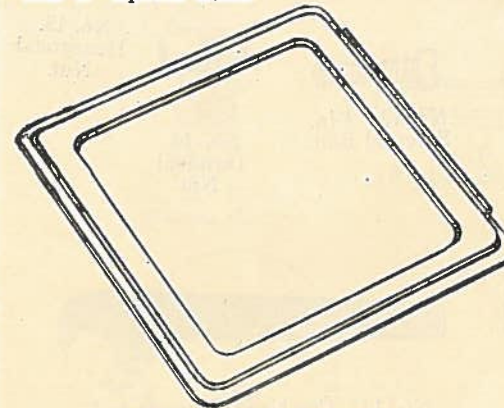

No. 2. Lid for Optical Box.

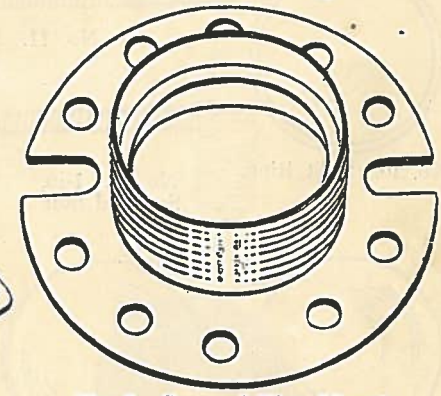

No. 3. Screwed Ring Mount.

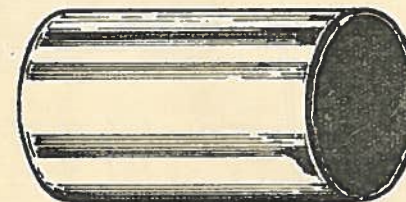

No. 4a. 1½-inch Optical Tube.

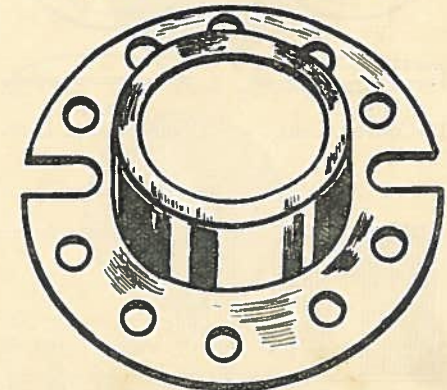

No. 3a. Plain Ring Mount.

HOW TO IDENTIFY INSTRUMENTS.

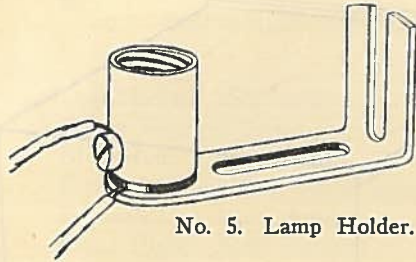

No. 5. Lamp Holder.

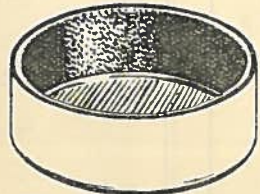

No. 6. Camera Cap.



No. 9. Small Pin-hole Disc. 1 inch diameter.

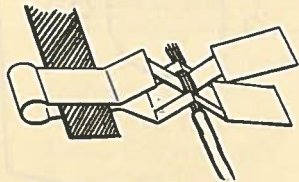

No. 7. Battery Clip.



No. 8. Distance Ring.



No. 6a. Camera Cap.



No. 10. Split Ring.



No. 11. 3-inch Screwed Rod.



No. 15. Hexagonal Nut.

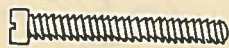

No. 12. 1-in. Screwed Bolt.

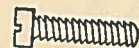

No. 13. 1/2-in. Screwed Bolt.



No. 14. Terminal Nut.



No. 17. Bi-Convex Lens.



No. 18. Plano-Convex Lens.



No. 16. Combined Spanner and Screwdriver.

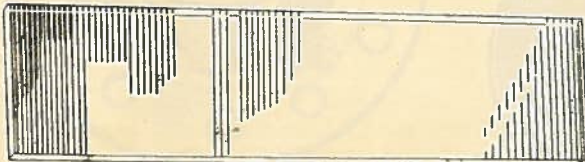
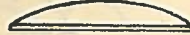

No. 19. Strip Mirror, 3" x 1 1/8".

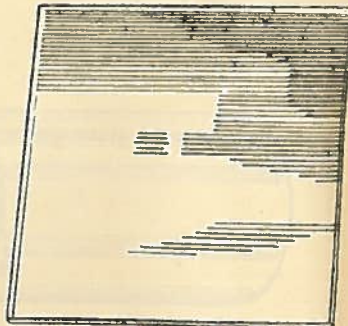

No. 20. Square Mirror.

HOW TO IDENTIFY INSTRUMENTS.

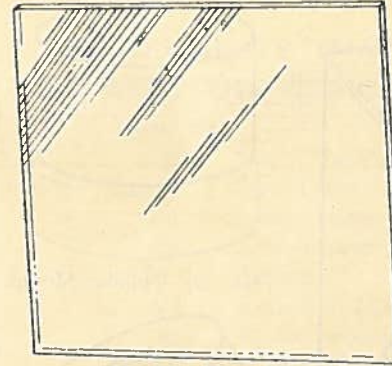

No. 21. Glass Plate.

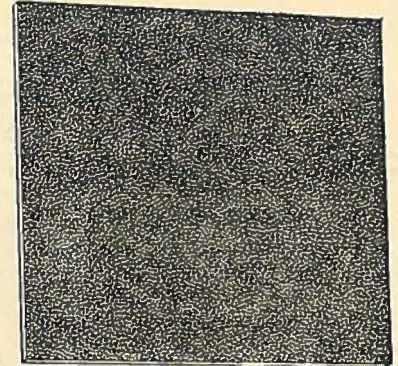

No. 22. Frosted Glass Plate.

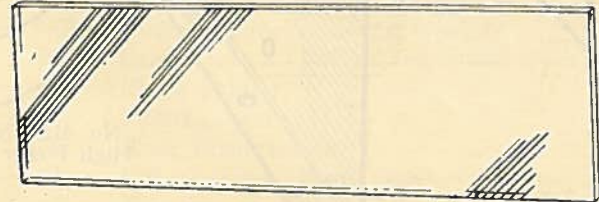

No. 23. Glass Slide.



No. 24. Focus Electric Bulb.



No. 37. Rubber Band.



No. 25. Bi-Convex Electric Bulb.

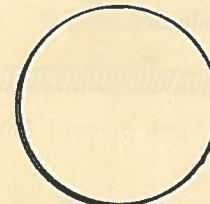

No. 26. Frosted Disc.



No. 37a. Lens Stop, 1/8" Aperture.



- No. 31. Red Opaque Disc.
- No. 32. Yellow Opaque Disc.
- No. 33. Green Opaque Disc.
- No. 34. Blue Opaque Disc.
- No. 35. White Opaque Disc.
- No. 36. Black Opaque Disc.

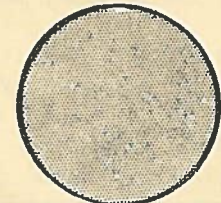

- No. 27. Red Transparent Disc.
- No. 28. Yellow Transparent Disc.
- No. 29. Green Transparent Disc.
- No. 30. Blue Transparent Disc.

HOW TO IDENTIFY CONSTRUMENTS.

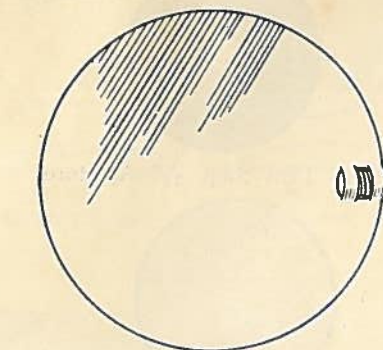
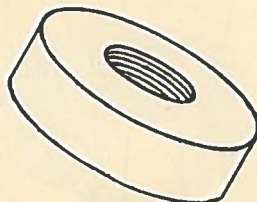
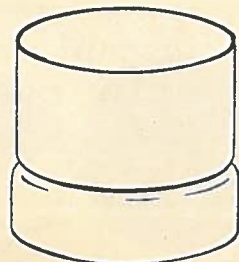
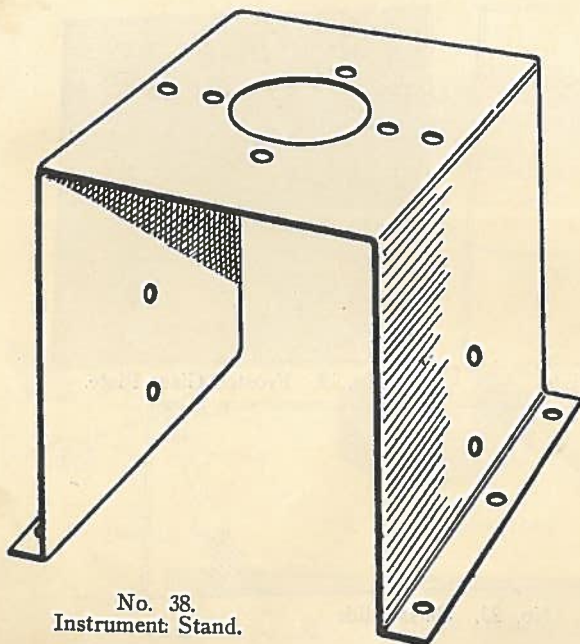
INSTRUMENTS THAT CAN BE CONSTRUCTED
WITH THE CONSTRUMENTS "10" OUTFIT.

13

Model No.	Description.
5	Low Power Magnifier (3 Leg type).
6	Low Power Magnifier (4 Leg type).
11	Low Power Magnifier (Stand type).
92	Low Power Magnifier (Stand type).
93 and 93A	Reflector.
94	Reflector (Lens type).
79	Reflectoscope.
95	Camera Lucida.
96	Pinhole Camera (Pocket type).
96A and 96B	Pinhole Camera (Stand type).
97	Lens Camera (Pocket and Stand types).
98	Photo Printer.
99	Photo Copier.
100	Slide Projector.
61	Kaleidoscope (Hand type).
62	Kaleidoscope (Magnifying Hand type).
101	Kaleidoscope (Stand type for transparent objects).
102	Kaleidoscope (Stand type for opaque objects).
103	Periscope.
104	Crazy Mirrors.
105	Crazy Mirrors (Stand type).
106	Ophthalmoscope.

INSTRUMENTS THAT CAN BE CONSTRUCTED
WITH THE CONSTRUMENTS "20" OUTFIT.

Model No.	Description.
1	Electric Torch.
2	Spot Light.
3	Signalling Lamp.
5	Low Power Magnifier (3 Leg type).
6	Low Power Magnifier (4 Leg type).
7	Low Power Magnifier (Box type for Opaque Objects).
10	Low Power Magnifier (Illuminated Box type).
13	Low Power Magnifier (Illuminated Box type).
29	Shadowscope for Dark Room.
30	Daylight Shadowscope (Horizontal Projection).
31	Shadowscope for Dark Room (Reflection type, suitable for Living Objects).
37	Camera Obscura (Toy Model).

Model No.	Description.
38	Pinhole Camera (Box type).
39	Pinhole Camera (Midget type).
41	Lens Camera (Short Range, Box type).
42	Lens Camera (Long Range, Box type).
43	Button Hole Picture Camera.
48	Electric Lamp Photo Printer.
50	Red Lamp for Dark Room.
61A and 61B	Hand Kaleidoscopes.
62A and 62B and 62C	Magnifying Kaleidoscopes.
63	Illuminated Kaleidoscope (Box type with Lamp).
66A and 66B	Reflection Kaleidoscopes (Box type).
67A and 67B	Reflection Kaleidoscopes (Projection type).
68A and 68B	Reflection Kaleidoscopes (Projection type).
69A and 69B	Hand Micro-Kaleidoscope.
76	Watch Projector (Reflection type).
87	Epidiascope.
93	Reflector.
94	Reflector (with Lens).
96	Midget Pinhole Camera.
97	Midget Lens Camera.
104	Crazy Mirrors.
106	Ophthalmoscope.

The following Models can also be made from the "20" Outfit by using an Optical Box (1) instead of the Instrument Stand (38).

79	Reflectoscope.
89	Picture Scanner.
95	Camera Lucida.
96A and 96B	Pinhole Camera and Stand.
98	Photo Printer.
99	Photo Copier.
100	Projector.
103	Periscope.
105	Crazy Mirrors.

INSTRUMENTS THAT CAN BE CONSTRUCTED WITH THE CONSTRUMENTS "100" OUTFIT.

Models 1 to 108 (excluding 27 and 28) can be constructed from the "100" Outfit.

GENERAL NOTES AND INSTRUCTIONS.

Before attempting to construct any of the models illustrated in this book, read carefully the following instructions. Having mastered these, no difficulty should be experienced in assembling the models with the help of the illustrations and notes.

A full list of Construments for each model is given, and these are indicated on the drawings to facilitate assembly.

MOUNTING LENSES, STOPS AND DISCS. (Fig. 1 and Fig. 2.)

Fig. 1 shows how Lenses (17) and (18), Stops (37a) and (44), and Discs (9) (26-30) and (45), may be mounted in one of four positions in the Ring Mount (3). Fig. 2 shows how the Lenses, Stops, or Discs are mounted when using Ring Mount (3a). It will be seen from Fig. 2 "A" and "B" that the Plano-Convex Lens (18) can be mounted with either the Plane or Convex face towards the front of the Mount, according to the model; this arrangement is also shown at "A," "B," "C," and "D," Fig. 1. After inserting the Lens, Stop, or Disc in the Ring Mount, it must be secured by a Split Ring (10) pressed down evenly all round; Fig. 2 "b" shows the Split Ring in position in Ring Mount (3a). When handling Lenses, always *hold by the edges*, as at "a" Fig. 2, as grease and minute scratches are fatal to the

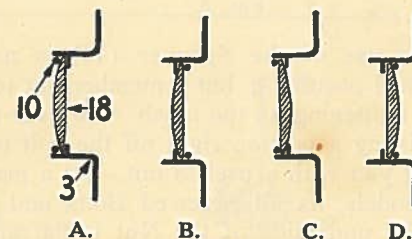

Fig. 1.

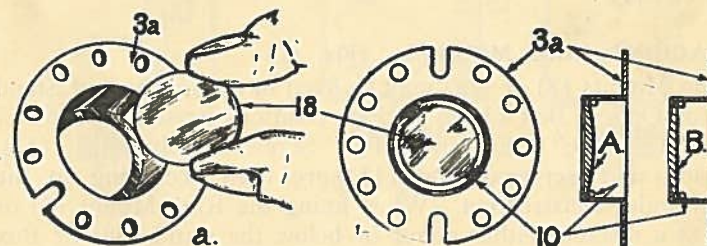

Fig. 2.

best optical results. Always use a soft silk handkerchief or chamois leather for polishing Lenses before inserting in the Mount.

SCREWED BOLTS AND RODS. (Fig. 3.)

When fixing Screwed Bolts (12), (13), or (46) in the Instrument Stand (38) or Optical Box (1) these should, wherever possible, be inserted in the holes from the inside as shown at "A," as it is easier to hold the head with the Screwdriver whilst the Nuts (15) are threaded on, than to manipulate the Spanner (16) within the Stand or Box. In the case of the Screwed Rods (11), first thread a Nut (15) on for a short distance, thus forming a "head," then insert in the holes as in the case of the bolts, as is shown in "B." It will be found, that by holding the Nut on the underside with the fingers, the upper one can be threaded on and screwed down tightly. As a rule, Nuts can be screwed down sufficiently tightly with the fingers to obtain a firm fixing, but there may be instances in assembling some of the

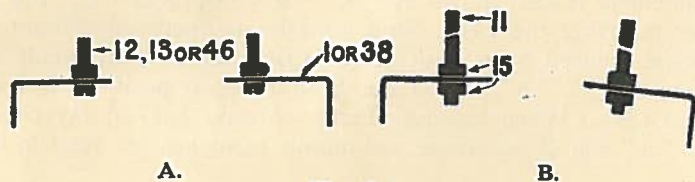

Fig. 3.

models where the use of the Spanner (16) is necessary, for instance in awkward positions; but remember not to damage the screw threads by tightening up too much. An over-tightened nut may result in twisting a portion right off the bolt or rod, at the same time leaving you with a useless nut. As a general rule, in assembling the models, fix all Screwed Bolts and Rods to the Stand first. If the underside of the Nut is flat and the top is slightly rounded, always see that the flat side is in contact when screwed up.

ATTACHING RING MOUNTS. (Fig. 4.)

Ring Mounts (3) or (3a) may be fixed to the Instrument Stand (38) or Optical Box (1) in various positions as shown at "A," "B," "C," "D," "E," and "F." Screwed Bolts (12), (13), or (46), and Screwed Rod (11) are used according to the model under construction. When fixing the Ring Mount (3) or (3a) at a distance either above or below the stand (38) or Box (1), as at "E" and "F," care should be taken to adjust the Nuts

so that the Mount is parallel with the Stand or Box, as failure to secure this adjustment will result in distortion of the image seen when using the Instrument.

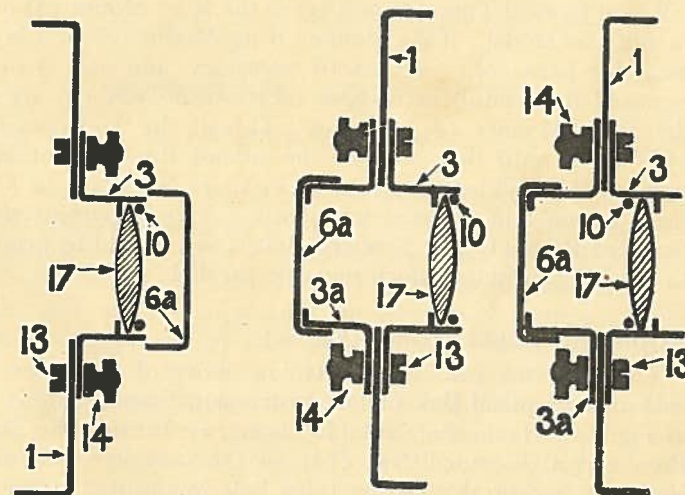
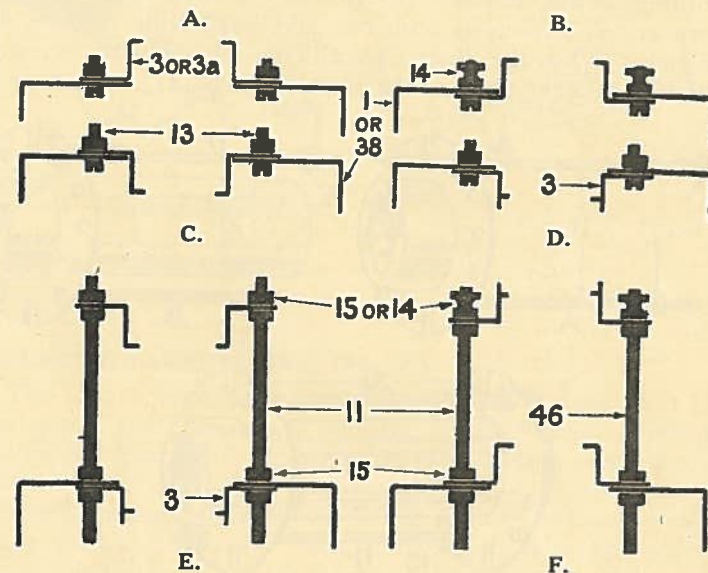

Model 41 (See page 49).

Model 42 (See page 50).

MOUNTING OPTICAL TUBES. (Fig. 5.)

Take a Ring Mount (3), or (3a), complete with assembled Lens (17) or (18), Stops (37a) or (44), Discs (9), (45), or (26)-(30), according to the model. Attach the Screwed Rods (11) as shown at "A" complete with two additional Nuts (16) on the free ends. When the Short Optical Tube (4a) is used, Screwed Bolts (46) take the place of the Screwed Rods (11). Insert as at

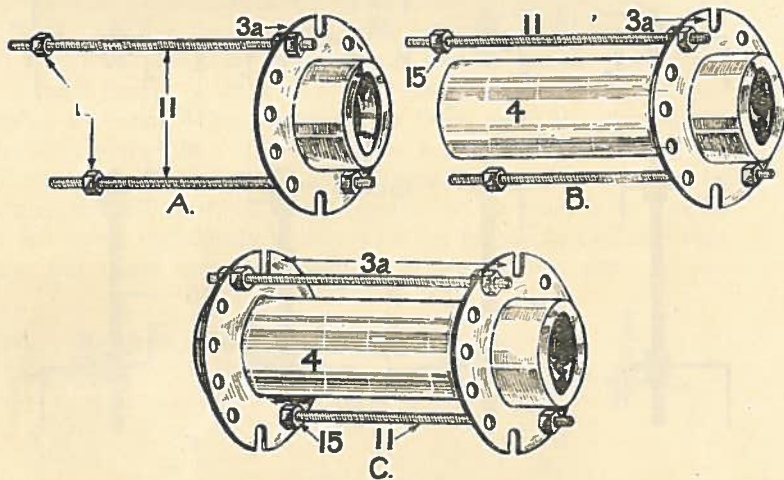

Fig. 5.

"B," an Optical Tube (4) or (4a) in the Ring Mount (3) or (3a), to suit the Model. Take another Ring Mount (3) or (3a), with Stop for Lens (37a), or Disc if necessary, and pass it over the Screwed Rods until the ends of the Optical Tube (4) are within the Ring Mounts (3) or (3a). Thread the Hexagonal Nuts (15) along until they support the second Ring Mount and the tube is held rigid between them; two more Nuts (14) or (15) are then put on and screwed up tightly. It is important that the Screwed Rods (11), or Screwed Bolts (46), should be firmly held to the Ring Mounts, which must be parallel.

MOUNTING REFLECTOR. (Fig. 6.)

The Reflector (42) is mounted in either of the holes on the side of the Optical Box (1), or Instrument Stand (38), as shown in Fig. 5, a Hexagonal Nut (15) being used inside the Stand or Box, and a Terminal Nut (14) on the outside. See that the Reflector is central with the large hole in the top of the Stand or Box.

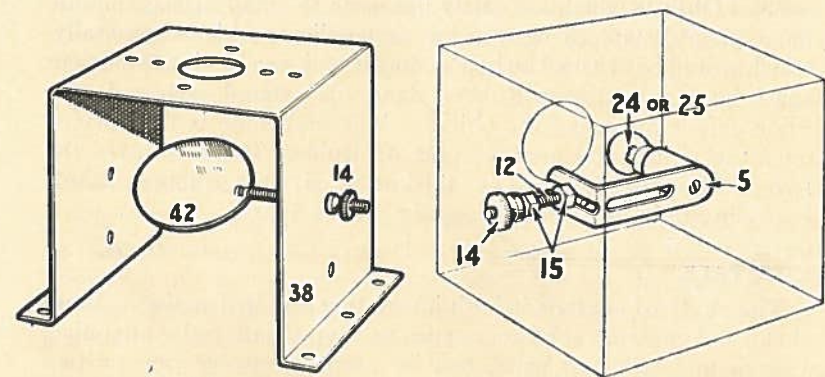

Fig. 6.

Fig. 7.

MOUNTING LAMPHOLDER. (Fig. 7.)

The Lampholder (5) is mounted on a lin. Screwed Bolt (12), the slot of the Lampholder allowing for any height adjustment within the Stand (38) or Box (1). The Bolt is secured to the Stand (38) or Box (1) with Nuts (14) and (15), as in the case of the Reflector, and as shown in Fig. 7, the upper or lower hole being used as required. See that the Lamp is central with the large hole in the top of the Stand (38) or Box (1). The slot in the Lampholder (5) allows for adjusting the position of the Lamp (24) or (25).

MICROSCOPE ACCESSORIES.*(Mounting Specimens.)***SLIDES.**

(1) Crystals of sugar, salt, fibres of cotton, wool, silk, hair, etc., cheese dust, pollen, tiny parts of flowers or insects, and many other minute objects may be mounted on Glass Slides (23) with the aid of a needle or knife blade. The specimens should not be crowded, and only a small quantity in the case of crystals and like subjects, being placed on the slide, especially when being used under a Compound Microscope (Models 25 and 26).

(2) Flat objects, or objects capable of being flattened, such as legs and wings of insects, small clippings of coloured cellophane (for Kaleidoscope Models, (61), (75), (101), and 102), pieces of fabric, silk, grasses, scales of fish, etc., may be mounted between Glass Slides (23) held together by Rubber Bands (37) Fig. 8A.

(3) Objects which are fairly flat, such as small insects, minute moss plants, stamens of flowers, and delicate objects generally, which would be crushed by being compressed, can be given sufficient space by first putting a Rubber Band (37) round each end of a Slide before mounting the object. A second Slide is then placed over the object and another pair of Rubber Bands secures the two Slides together. The thickness of the Rubber Bands encircling only one Slide, keeps the Slides apart.

CRYSTALS.

The study of crystals is both interesting and instructive. Many cheap and common substances such as Hypo, Salt, Sal Ammoniac, Epsom and Glauber Salts, can be used. Dissolve one or two crystals in a very small quantity of water and transfer with the Collecting Tube (47), a few drops of the solution to a clean slide, as shown in Fig. 9. See that both the Tube and the Slide are perfectly clean and free from dust.

Cover the slide over to exclude dust, and leave over night, when crystals will probably have formed.

Medium Power Microscopes are most suitable for observing crystals.

LIVE BOX. (Fig. 8B.)

For viewing living matter, insects, etc., a suitable Box can be constructed by mounting the Distance Ring (8) between two Glass Slides (23) secured by Rubber Bands (37).

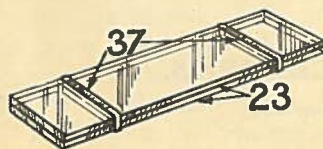

Fig. 8A.

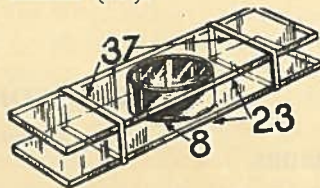

Fig. 8B.

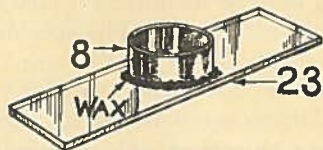

Fig. 8C.

AQUARIUM. (Fig. 8C.)

Specimens of Pond Water, Crystal Solutions, etc., may be examined with the aid of the Aquarium shown, which is easily

constructed. Mount the Distance Ring (8) on a Glass Slide (23) using Candle Wax, Plasticene, Putty, Gum, or other suitable material to form a watertight joint between the Ring and the Slide. The Aquarium is filled by means of the Collecting Tube (47) as shown in Fig. 9.

LIVING MATTER. (Fig. 9.)

Interesting samples of living matter can be secured from ponds or the sea-shore. Always select a pond with plenty of green growth, and in the case of sea-water, stir up the sand at the bottom before obtaining your sample. A convenient collecting accessory can be made as follows:—

Cut a hole in the bottom of a fishing-net to take the mouth of a jar, and tie round the neck with string.

This can be dipped into the water for specimens. Some of the larger ones will be seen moving about, but the more minute objects will be discovered when the water is examined under the microscope.

To fill the Aquarium, take the Collecting Tube (47) and place your finger over the end. Lower the Tube into the specimen jar and remove the finger; the water will rise in the tube; now replace your finger over the end, and withdraw the Tube. Hold the Tube over the Aquarium and release the contents into it by removing your finger.

Some of the larger specimens can be captured quite easily, as the Tube can be placed directly over them.

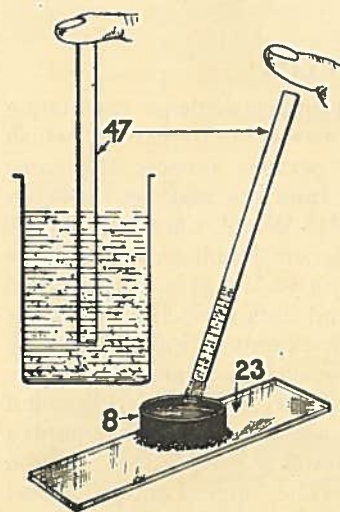

Fig. 9.

HIGH POWER OBJECTIVES. (Fig. 10.)

The High Power Objectives (41) and (48) may be mounted in their respective Mounts (41a) and (48a), with the Lens as at "A" or "B." The assembly is screwed on to the Ring Mount (3). Two adjustments for focus are therefore available when using Objective (41) and Mount (41a), but in the case of the

Improved Objective, the Mount (48a) is screwed up tightly on the Ring Mount (3), complete adjustment being obtained on the Objective (48).

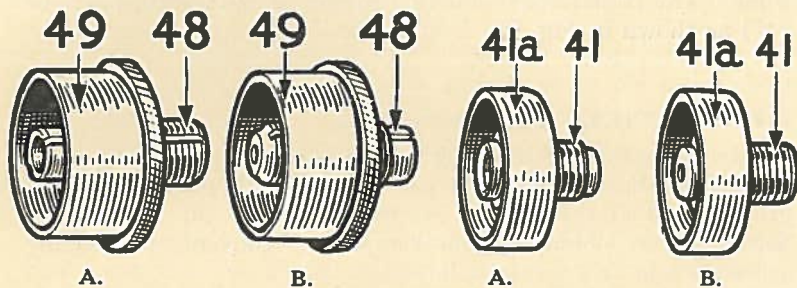

Fig. 10.

FINGER PRINTS.

A collection of finger and thumb-prints provides a fascinating pastime, especially if each impress bears the signature, which should be in black ink. No two persons possess the same markings revealed by an impress. Imprints may be made on Glass Slides (23), Glass Plates (21), White Card, or Paper. When making an impress, the finger or thumb should first be dipped in some material, such as face powder, grease paint, boot polish, or rubbed on a piece of coal and then pressed on the glass or paper. Slides and plates may be examined in a variety of ways, for instance through a Magnifier such as Models 5, 6, 7, 15, 16, and 17 or Microscope Models 18, 19, and 20, dark ground illumination being used. They can also be copied or enlarged with Model 47, photographed with Model 58, or printed direct on photographic paper, using Model 49. The Magic Lantern, Model 51, can be used to project a picture on a screen or white wall, or daylight projection may be made on the Frosted Glass Plate (22) of Models, 52, 53, 54, 55, or 56.

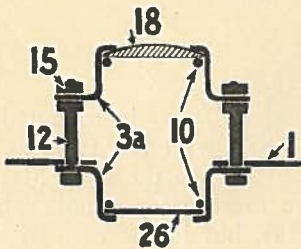

Fig. 11. Shows the method of mounting the Lens (18) in Model 7 and the method of mounting the Frosted Disc (26) in Models 10 and 13.

ELECTRIC TORCHES, SPOTLIGHTS, ETC.

MODEL 1.—ELECTRIC TORCH.

Parts required :—

2 Plain Ring Mounts	(3a)
1 Optical Tube	(4)
1 Lampholder	(5)
2 Battery Clips	(7)
1 Split Ring	(10)
2 3in. Screwed Rods	(11)
1 1in. Screwed Bolt	(12)
5 Terminal Nuts	(14)
6 Hexagonal Nuts	(15)
1 Bi-Convex Lens	(17)
1 Focus Electric Bulb	(24)
4 Transparent Discs	(27-30)
Battery	

Insert the Bi-Convex Lens (17) in one of the Ring Mounts (3a) and secure with the Split Ring (10). Complete the Optical Tube assembly as shown (see A, B, and C., Fig. 5, p. 18). Insert the 1in. Screwed Bolt (12) in the Ring Mount (3a) (without the Lens) and secure with Hexagonal Nut (15). Thread on another Hexagonal Nut (15) and place the Lampholder (5) complete with the Focus

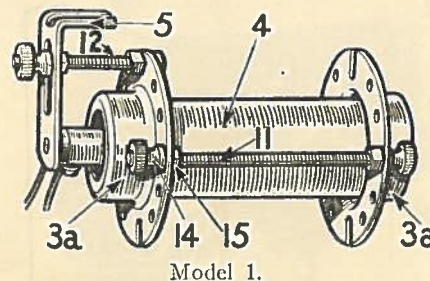

Electric Bulb (24) on the 1in. Screwed Bolt and lock with the Terminal Nut (14). It is important that the Focus Electric Bulb (24) should be central with the Optical Tube (4), and focussed to give the correct beam. Adjustment for focus is obtained by positioning the Lampholder (5) using the Screwed Bolt (12) so that an evenly illuminated and nearly parallel beam is thrown on to the object. The uses of a torch are numerous, but mention may be made of a bedside lamp and bicycle lamp. The use of coloured discs (27-30) behind the Lens (18) will be found to produce some interesting results.

MODEL 2.—SPOTLIGHT.

Parts required :—

1	Optical Box	(1)
1	Lid for Optical Box	(2)
1	Plain Ring Mount	(3a)
1	Lampholder	(5)
2	Battery Clips	(7)
1	Split Ring	(10)
1	1in. Screwed Bolt	(12)
2	$\frac{1}{2}$ in. Screwed Bolts	(13)
3	Terminal Nuts	(14)
2	Hexagonal Nuts	(15)
1	Bi-Convex Lens	(17)
1	Focus Electric Lamp	(24)
4	Transparent Discs	(27-30)
	Battery	

Place the Bi-Convex Lens (17) in the Ring Mount (3a) and secure with a Split Ring (10). Coloured Discs (27-30) may be used behind the Lens. Fix the completed

Lens Mount to the Optical Box (1) with $\frac{1}{2}$ in. Screwed Bolts (13) and Terminal Nuts (14) as shown. Mount the Lampholder (5) on the 1in. Screwed Bolt (12) and fix in the lower hole of the Optical Box with Nuts (14) and (15). Pass the Battery leads through the other hole and slide on the Lid (2). It is important that the Lampholder (5) should be adjusted on the Screwed Bolt (12) for focus, and that the Focus Electric Lamp (24) is central in the Box.

This Model is used for projecting coloured light in stage work, and some interesting shadow effects can be obtained in a dark room with coloured light. The strong beam will carry to a considerable distance.

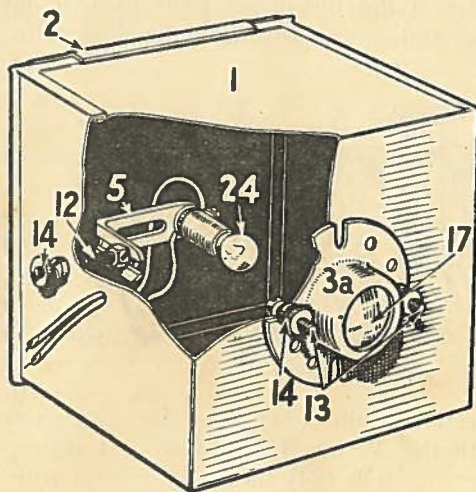

Model 2.

MODEL 3.—SIGNALLING LAMP.

Parts required :—

1	Optical Box	(1)
1	Lid for Optical Box	(2)
2	Plain Ring Mounts	(3a)
1	Optical Tube	(4)
1	Lampholder	(5)
1	Battery Clip	(7)
1	Split Ring	(10)
2	3in. Screwed Rods	(11)
1	1in. Screwed Bolt	(12)
3	Terminal Nuts	(14)
12	Hexagonal Nuts	(15)
1	Bi-Convex Lens	(17)
1	Focus Electric Bulb	(24)
4	Transparent Discs	(27-30)

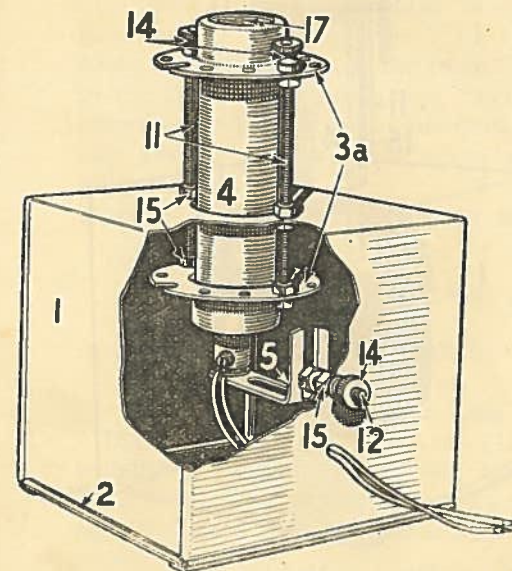

Model 3.

Mount Model 1 without the Lampholder and attachments, to Optical Box (1) as in the picture. Mount a Lampholder (5) and Focus Electric Bulb in the central hole of the Optical Box (1) as shown (see also Fig. 7, p. 19).

This is a useful Model for Scouts and Guides, enabling the transmission of signals to be made in Morse Code, with either white or coloured light, and in the dark. The signals are made by completing the electric circuit through the battery and

lamp with the bare end of one of the leads, the other being fixed to the battery with a Clip (7). A Tapping Key can be inserted in the circuit if desired.

MODEL 4.—SIGNALLING LAMP. (Reflecting Type.)

Parts required:—

1	Screwed Ring Mount	(3)
2	1in. Screwed Bolts	(12)
1	$\frac{1}{2}$ in. Screwed Bolt	(13)
7	Hexagonal Nuts	(15)
1	Mirror (2in. x 2in.)	(20)
2	2in. Screwed Bolts	(46)

The previous Model (3) can be converted into this one by the addition of a Mirror and Mirror Stand (Model 93). By means of the Mirror, signals are projected horizontally as in the case of the heliograph, an instrument in common use for daylight signalling. First assemble the Mirror Stand (Model 93), using Ring Mount (3a) 1in. Screwed Bolts (12) and the $\frac{1}{2}$ in. Screwed Bolt (13) as shown. Place the Stand on top of the upper Ring Mount (3) of the Model and clamp the two together with 2in. Screwed Bolts (46) and Hexagonal Nuts (15) as shown.

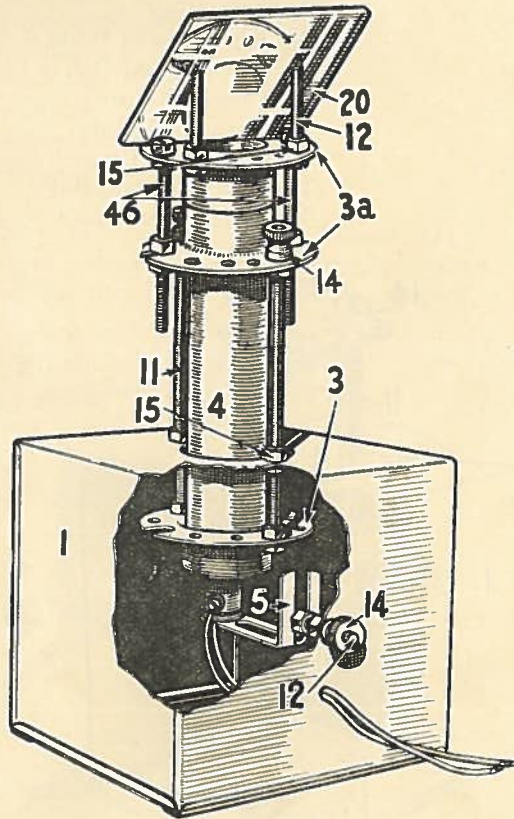

Model 4.

HINTS ON THE USE OF MAGNIFIERS AND MICROSCOPES.

Illumination of Objects. If the object is transparent, e.g., a fly's wing, it should be illuminated from below with either the Reflector (42) or the Focus Electric Bulb (24). Care should be taken to get the angle of the Reflector (42) or the position of the

Focus Electric Bulb (24) exactly right, so that a good light is concentrated on the object to be viewed without glare. When using the Lamp mount a Frosted Disc (26) below the object for a Medium Power Microscope and the Large Pinhole Disc (45) for a High Power Microscope. The Lamp should be mounted as low as possible, and the best position found by adjusting the position of the Lampholder (5).

If the object is opaque, it should be illuminated from the side or above, and it may be best, in some cases, to use a dark background. This is known as Dark Ground Illumination. It is advisable to experiment with both Dark and Light Ground Illumination, especially when using Medium Power Microscopes. The black side of the Optical Box Lid (2) may often be useful for this purpose.

SIMPLE MAGNIFIERS.

As their name implies, these instruments must not be expected to give a high degree of magnification, but are very useful in many ways. The illuminated Models (9-13) give particularly good results. In the Models, 9, 10, 11, 12, and 13, it is interesting to try either the Lamp, or the Reflector, in the upper or lower hole in the side of the Instrument Stand (38) or Optical Box (1) according to the degree of illumination required. The reflector may also be tried with the white side or polished side as the reflecting surface.

MODELS 5 and 6.—LOW POWER MAGNIFIERS. (3 and 4 Leg Type.)

Parts required:—

1	Plain Ring Mount	(3a)
1	Split Ring	(10)
4	1in. Screwed Bolts	(12)
4	Hexagonal Nuts	(15)
1	Plano-Convex Lens	(18)

Insert the Plano-Convex Lens (18) in the Ring Mount (3a) with the curved or Convex side uppermost. Secure with Split Ring (10). Mount the assembly on three Screwed Bolts (12) equally spaced as shown (Model 5).

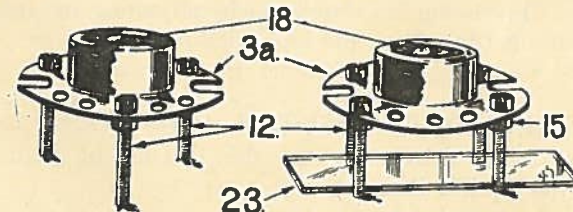

Model 5.

Model 6.

By the addition of another 1in. Screwed Bolt (12) and Hexagonal Nut (15); (the four Bolts being spaced round the Ring Mount (3a) as in Model 6), it is possible to pass objects mounted on Glass Slides (23) between the legs of the Stand.

Model 5 is extremely useful for the examination of detail, where a high magnification is not required, in objects such as postage stamps, crests, coins, maps, pictures, watch parts, finger-prints, etc.

MODEL 7.—LOW POWER MAGNIFIER. (Box Type for Opaque Objects.)

Parts required:—

- | | |
|-----------------------|------|
| 1 Optical Box | (1) |
| 1 Lid for Optical Box | (2) |
| 1 Plain Ring Mount | (3a) |
| 1 Split Ring | (10) |
| 2 1in. Screwed Bolts | (12) |
| 2 Terminal Nuts | (14) |
| 4 Hexagonal Nuts | (15) |
| 1 Plano-Convex Lens | (18) |

Mount the Plano-Convex Lens (18) as in the previous Models (5 and 6). Pass the 1in. Screwed Bolts (12) through the holes in the top of the Optical Box (1) from the inside and secure with Hexagonal Nuts (15). Add two more Hexagonal Nuts (15)

and place the completed Mount on the 1in. Screwed Bolts (12) and lock in position with the Terminal Nuts (14) as shown. See that the Mount is parallel with the top of the Optical Box (1).

Opaque objects such as cloth, feathers, leaves, etc., mounted on Glass Slides (23) can be examined with this Model, the top of the Optical Box (1) acting as a stage for supporting the Slides (23). Focussing is carried out by adjusting the height of the Ring Mount (3a) above the Optical Box (1).

MODEL 8.—LOW POWER MAGNIFIER. (Stand Type.)

Construct as Model 7, but use the Instrument Stand (38) instead of the Optical Box (1).

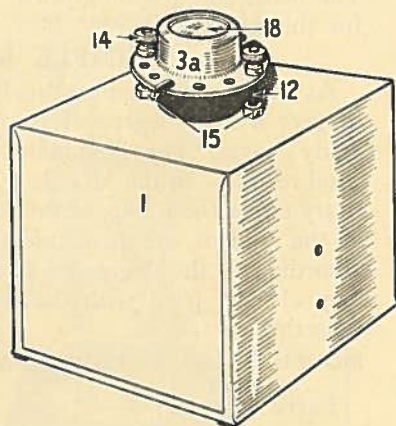

Model 7.

MODEL 9.—LOW POWER MAGNIFIER. (Stand Type with Reflector.)

Construct as Model 7, but use the Instrument Stand (38) with the Reflector (42) attached to it instead of the Optical Box (1). The Reflector (42) is attached to the Instrument Stand (38) as in Fig. 6, p. 27.

MODEL 10.—LOW POWER MAGNIFIER. (Illuminated Box Type.)

Parts required:—

- | | |
|-----------------------|---------|
| 1 Optical Box | (1) |
| 1 Lid for Optical Box | (2) |
| 1 Lampholder | (5) |
| 2 Plain Ring Mounts | (3a) |
| 2 Battery Clips | (7) |
| 2 Split Rings | (10) |
| 2 3in. Screwed Rods | (11) |
| 1 1in. Screwed Bolts | (12) |
| 3 Terminal Nuts | (14) |
| 6 Hexagonal Nuts | (14) |
| 1 Bi-Convex Lens | (17) |
| 1 Focus Electric Lamp | (24) |
| 1 Frosted Disc | (26) |
| 4 Coloured Discs | (27-30) |

Fix a Ring Mount (3a) to the underside of the top of the Optical Box (1), with Screwed Rods (11) and Hexagonal Nuts (15) as shown, leaving approximately 2½in. of the 3in. Screwed

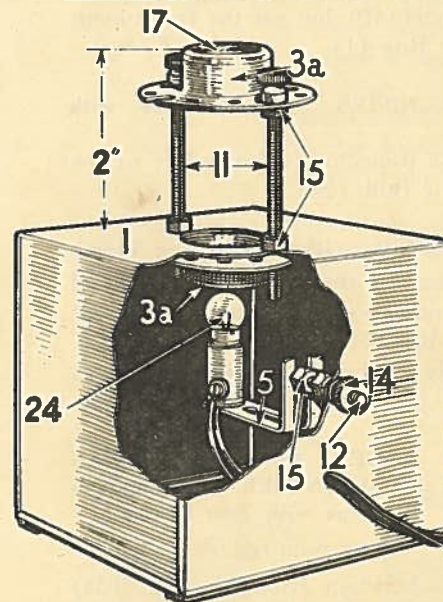

Model 10.

Rods (11) above the Optical Box (1). Mount the Lampholder (5) and Lamp (24) as in Fig. 7, p. 28, on the Screwed Bolt (12). The Bi-Convex Lens (17) should now be inserted in the other Ring Mount (3a) and the Mount assembled on the Rods at approximately 2in. from the Box. Adjust the Lampholder (5) central in the Optical Box (1) and at a distance from the Ring Mount (3a) to give a good illumination without the image of the Lamp appearing on the Frosted Disc (26) when viewed from above; this will be found to be approximately as shown.

For the examination of transparent objects such as wings of insects, certain flower petals, fish scales, soap films, etc., and semi-transparent subjects, for instance, crystals, mica, celluloid, films, silks, etc., this Model will be found useful. When viewing semi-transparent subjects, the Frosted Disc (26) should be removed from the lower Ring Mount (3a). Contrasting illumina-

tion may be obtained by using the coloured Discs (27-30) as for instance in the case of whitish objects. Focussing is carried out by adjusting the height of the upper Ring Mount (3a) above the Box. Always keep the top of the Optical Box (1) and Ring Mount (3a) parallel.

MODEL 11.—LOW POWER MAGNIFIER. (Illuminated Stand Type.)

Construct as in the previous Model (10), but use the Instrument Stand (38) instead of the Optical Box (1).

MODEL 12.—LOW POWER MAGNIFIER. (Stand Type with Reflector.)

Construct as Model 11 using the Reflector (42) in place of the Lampholder (5) and Focus Electric Bulb (24).

MODEL 13.—LOW POWER MAGNIFIER. (Illuminated Box Type.)

This Model is constructed in exactly the same way as Model 7, 1in. Screwed Bolts (12) being used to support the Ring Mount (3) instead of the Screwed Rods (11). See Fig. 11, p. 29. A Lamp (24) is mounted centrally in the Optical Box (1) as in Fig. 7, p. 19.

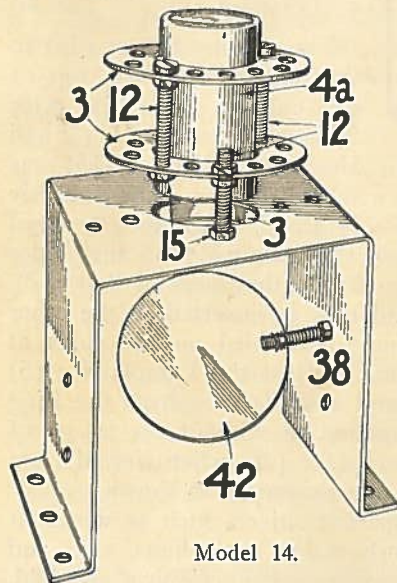

Model 14.

Screwed Bolts (12) and Hexagonal Nuts (15). The Ring Mount (3a) containing the Bi-Convex Lens (17) is the eyepiece of the Instrument.

MODEL 14.—LOW POWER MAGNIFIER. (Compound Type with Two Lenses.)

Parts required :—

- | | |
|----------------------|------|
| 2 Plain Ring Mounts | (3a) |
| 1 Optical Tube | (4a) |
| 2 Split Rings | (10) |
| 2 2in. Screwed Bolts | (12) |
| 6 Hexagonal Nuts | (15) |
| 1 Bi-Convex Lens | (17) |
| 1 Plano-Convex Lens | (18) |

Insert the Plano-Convex Lens (18) in one Ring Mount (3a), and the Bi-Convex Lens (17) in the other, securing each with a Split Ring (10). Mount the Optical Tube (4a) between the Ring Mounts (3a) as shown with the 1in.

MEDIUM POWER MAGNIFIERS.

A higher degree of magnification is obtainable with the following Models owing to the Lens arrangement.

MODEL 15.—MEDIUM POWER MAGNIFIER. (Hand Type.)

Parts required :—

- | | |
|-------------------------|------|
| 1 Screwed Ring Mount | (3) |
| 1 Distance Ring | (8) |
| 1 Split Ring | (10) |
| 2 Plano-Convex Lenses | (18) |
| 1 Tubular Mount | (39) |
| 1 Cap for Tubular Mount | (40) |

The Lenses (18) are inserted in the Tubular Mount (39) as shown diagrammatically, and separated by the Distance Ring (8). Screw the lens assembly on to the Screwed Ring Mount (3) and fit on the Tubular Cap (40).

For examining detail parts of micro slides or photographic negatives this Model will be found most useful. The Model is placed directly on the Slide or negative to be examined and held up to direct light.



Model 15.

Model 16.

MODEL 16.—MEDIUM POWER MAGNIFIER. (Desk Type.)

Parts required :—

- | | |
|-------------------------|------|
| 1 Screwed Ring Mount | (3) |
| 2 Split Rings | (10) |
| 3 ½in. Screwed Bolts | (13) |
| 3 Hexagonal Nuts | (15) |
| 2 Plano-Convex Lenses | (18) |
| 1 Tubular Mount | (39) |
| 1 Cap for Tubular Mount | (40) |

Mount the Lenses (18) as shown. Insert the ½in. Screwed Bolts (13) in the Screwed Ring Mount (3) at equal distances

apart and secure with Hexagonal Nuts (15). Screw the two Screwed Ring Mounts (3) together and fit on the Cap for the Tubular Mount (40).

In this Model the Lenses (18) are arranged at a greater distance from the object, as shown, the Instrument being mounted on three legs. Prints, fabrics, drawings, process blocks, and various other subjects can be minutely examined with this Model.

MODEL 17.—MEDIUM POWER MAGNIFIER. (Four Leg Type with Stage.)

Parts required:—

- | | |
|-------------------------|------|
| 1 Screwed Ring Mount | (3) |
| 1 Plain Ring Mount | (3a) |
| 2 Split Rings | (10) |
| 4 1in. Screwed Bolts | (12) |
| 12 Hexagonal Nuts | (15) |
| 2 Plano-Convex Lenses | (18) |
| 1 Tubular Mount | (39) |
| 1 Cap for Tubular Mount | (40) |

This Model is exactly the same as the previous one (Model 16) as regards the Lens arrangement. An extra Ring Mount acts as a stage for supporting slides.

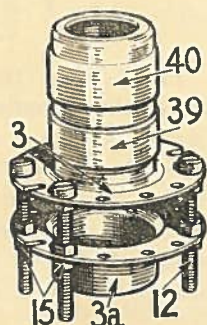

Model 17.

Mount the Lenses as in the previous Model 16. The four Screwed Bolts (12) are then fitted to the Screwed Ring Mount (3), spaced as shown, and locked with Hexagonal Nuts (15). Thread on to each 1in. Screwed Bolt (12) another Hexagonal Nut (15) and pass the 1in. Screwed Bolts (12) through holes in the Plain Ring Mount (3a) and lock with Hexagonal Nuts (15) as shown. Adjust the nuts holding the Lower Plain Ring Mount (3a) so that the Mount is parallel with the upper one, and just clear when the instrument is standing.

HIGH POWER SIMPLE MICROSCOPES.

Before using any of the Microscopes in this section it is advisable to read the section on Microscope Accessories, etc., on pages 19-21.

The following three Models are made by using the High Power Objective (41) screwed *downwards*, as in Fig. 10, page 22, into the Mount (41a)—the whole being then screwed to a Ring Mount (3) as shown in the first picture below. Note that the

field of view, though small, gives a high magnification, and only very tiny objects can be seen all at once. Note also that the High Power Objective must be very close to the object. You get the right focus by screwing the Objective or the Mount either up or down.

MODEL 18.—HIGH POWER SIMPLE MICROSCOPE. (Slide Type.)

Parts required:—

- | | |
|----------------------------------|-------|
| 1 Screwed Ring Mount | (3) |
| 1 High Power Objective | (41) |
| 1 Mount for High Power Objective | (41a) |

This Model is used for placing directly upon a microscopic slide and then holding both slide and magnifier up to the light, with the eye very close to the hollow end of the Objective (41).

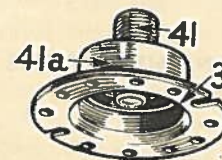

Model 18.

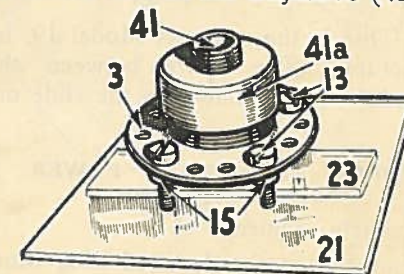

Model 19.

MODEL 19.—HIGH POWER SIMPLE MICROSCOPE. (Pocket or Desk Type.)

Parts required:—

- | | |
|----------------------------------|-------|
| 1 Screwed Ring Mount | (3) |
| 4 ½in. Screwed Bolts | (13) |
| 4 Hexagonal Nuts | (15) |
| 1 Glass Plate | (21) |
| 1 High Power Objective | (41) |
| 1 Mount for High Power Objective | (41a) |

This is the same as Model 18, but mounted on four ½in. Screwed Bolts (13) inserted in the four holes of the Ring Mount on either side of the slots. (Model 17 shows this position of the bolts.) This again is for viewing microscopic slides, which should be placed between the four legs of the magnifier after first placing the magnifier on the Glass Plate (21). Glass Plate, Slide,

and Magnifier can then all be raised to the light for viewing. Note that the High Power Lens must be close up to the object viewed. Both Objective (41) and Mount (41a) should therefore be screwed well down to secure the right focus.

MODEL 20.—HIGH POWER SIMPLE MICROSCOPE. (Four Leg Type with Stage.)

Parts required:—

- | | |
|----------------------------------|-------|
| 1 Screwed Ring Mount | (3) |
| 1 Plain Ring Mount | (3a) |
| 4 1in. Screwed Bolts | (12) |
| 12 Hexagonal Nuts | (15) |
| 1 High Power Objective | (41) |
| 1 Mount for High Power Objective | (41a) |

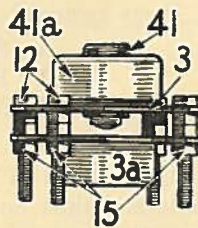

Model 20.

This is the same as Model 19, but mounted as shown in the picture. The space between the two Ring Mounts (3) and (3a) accommodates the slide or object to be viewed.

MODEL 21.—MEDIUM POWER DISSECTION MICROSCOPE. (Stand Type.)

Parts required:—

- | | |
|---------------------------|------|
| 1 Screwed Ring Mount | (3) |
| 1 Lampholder | (5) |
| 2 Split Rings | (10) |
| 3 1in. Screwed Bolts | (12) |
| 3 Terminal Nuts | (14) |
| 6 Hexagonal Nuts | (15) |
| 2 Plano-Convex Lenses | (18) |
| 1 Bi-Convex Electric Bulb | (25) |
| 1 Frosted Disc | (26) |
| 1 Instrument Stand | (38) |
| 1 Tubular Mount | (39) |
| 1 Cap for Tubular Mount | (40) |

First assemble the Lenses (18) as shown in the diagram on page 35, one in the Ring Mount (3), and one in the Tubular Mount (39). Now mount on the Instrument Stand (38) by means of two 1in. Screwed Rods as shown, and mount the Bi-Convex Electric Bulb in the side of the Stand (as in Fig. 7, page 19). A strong diffused light can be obtained for examining transparent objects by fitting an extra Ring Mount to

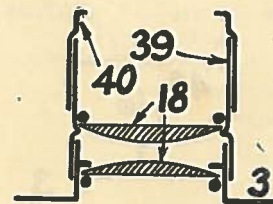

Lens arrangement for Model 21.

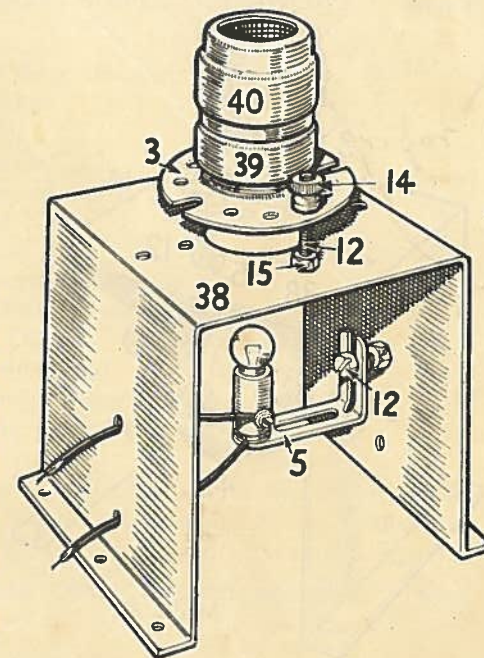

Model 21.

the under side of the Stand as in Model 23, and placing a Plano-Convex Lens curved side downwards in the Ring Mount from below, as in Fig. 1, page 15, and the Frosted Disc (26) into the lower Ring Mount from above. The lower Lens thus concentrates the light and the Frosted Disc (26) prevents it being too brilliant. The slide or object to be viewed is then placed on top of the Instrument Stand (38) between the Frosted Disc and the upper Lenses.

NOTE.—The Optical Box (1) may be used instead of the Instrument Stand if desired.

MODEL 22.—MEDIUM POWER DISSECTION MICROSCOPE. (Stand Type. As Model 21 but with Reflector.)

Parts required:—

- | | |
|-------------------------|------|
| 1 Screwed Ring Mount | (3) |
| 2 Split Rings | (10) |
| 2 1in. Screwed Bolts | (12) |
| 3 Terminal Nuts | (14) |
| 5 Hexagonal Nuts | (15) |
| 2 Plano-Convex Lenses | (18) |
| 1 Instrument Stand | (38) |
| 1 Tubular Mount | (39) |
| 1 Cap for Tubular Mount | (40) |
| 1 Reflector | (42) |

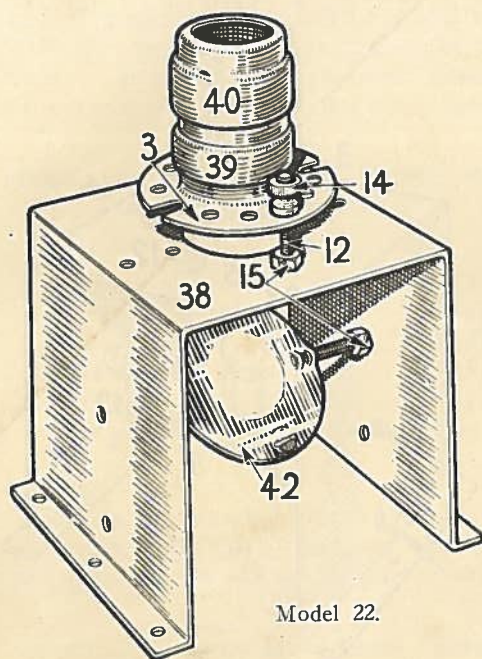

Model 22.

results with the objects to be viewed.

MODEL 23.—HIGH POWER SIMPLE MICROSCOPE. (Stand Type.)

Parts required:—

- | | | |
|---|---------------------------------|-------|
| 2 | Screwed Ring Mounts | (3) |
| 1 | Split Ring | (10) |
| 2 | $\frac{1}{2}$ in. Screwed Bolts | (13) |
| 3 | Terminal Nuts | (14) |
| 5 | Hexagonal Nuts | (15) |
| 1 | Plano-Convex Lens | (18) |
| 1 | Instrument Stand | (38) |
| 1 | High Power Objective | (41) |
| 1 | Mount for High Power Objective | (41a) |

Attach Model 18 to the Instrument Stand (38) as shown.

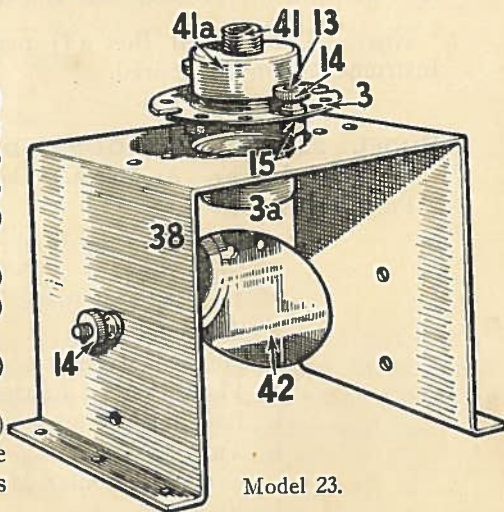

Model 23.

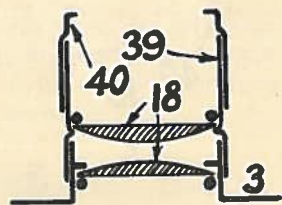

Lens arrangement for Model 22.

Construct Model 22 as Model 21, but substitute a Reflector (42) for the Lampholder and Lamp.

The Reflector (42) may be used in either centre or lower hole of the Instrument Stand (as in Fig. 6, page 19). Try also using either the white or the polished side of the Reflector to see which gives the best

MODEL 24.—HIGH POWER SIMPLE MICROSCOPE. (Stand Type A.)

Parts required:—

- | | | |
|---|---------------------------------|-------|
| 2 | Screwed Ring Mounts | (3) |
| 1 | Lampholder | (5) |
| 1 | Split Ring | (10) |
| 1 | 1in. Screwed Bolt | (12) |
| 2 | $\frac{1}{2}$ in. Screwed Bolts | (13) |
| 3 | Terminal Nuts | (14) |
| 6 | Hexagonal Nuts | (15) |
| 1 | Plano-Convex Lens | (18) |
| 1 | Focus Electric Bulb | (24) |
| 1 | Frosted Disc | (26) |
| 1 | Instrument Stand | (38) |
| 1 | High Power Objective | (41) |
| 1 | Mount for High Power Objective | (41a) |

Model 24 is exactly as Model 23 but with the Frosted Disc (26) in the lower Ring Mount (3) and the Focus Lamp (24) used instead of the Reflector (42) and mounted as in Fig. 7, p. 19.

MODEL 25.—HIGH POWER COMPOUND MICROSCOPE. (With Lamp.)

Parts required:—

- | | | |
|----|---------------------------------|-------|
| 2 | Screwed Ring Mounts | (3) |
| 1 | Plain Ring Mount | (3a) |
| 1 | Optical Tube | (4) |
| 1 | Lampholder | (5) |
| 1 | Distance Ring | (8) |
| 3 | Split Rings | (10) |
| 2 | 3in. Screwed Rods | (11) |
| 1 | 1in. Screwed Bolt | (12) |
| 2 | $\frac{1}{2}$ in. Screwed Bolts | (13) |
| 5 | Terminal Nuts | (14) |
| 14 | Hexagonal Nuts | (15) |
| 3 | Plano-Convex Lenses | (18) |
| 1 | Focus Electric Bulb | (24) |
| 1 | Instrument Stand | (38) |
| 1 | Tubular Mount | (39) |
| 1 | Cap for Tubular Mount | (40) |
| 1 | High Power Objective | (41) |
| 1 | Mount for High Power Objective | (41a) |
| 2 | Spring Clips | (43) |
| 1 | Large Pinhole Disc | (45) |
| 2 | 2in. Screwed Bolts | (46) |

This is a very effective instrument giving a high degree of magnification to microscopic subjects. To construct this Model, first of all make-up the Eyepiece from two Plano-Convex Lenses (18), Distance Ring (8), and Tubular Mount (39) and Cap (40) exactly as Model 15. Then mount the Optical Tube (4) between two Ring Mounts (3).

Now take the High Power Objective (41) and screw it for a

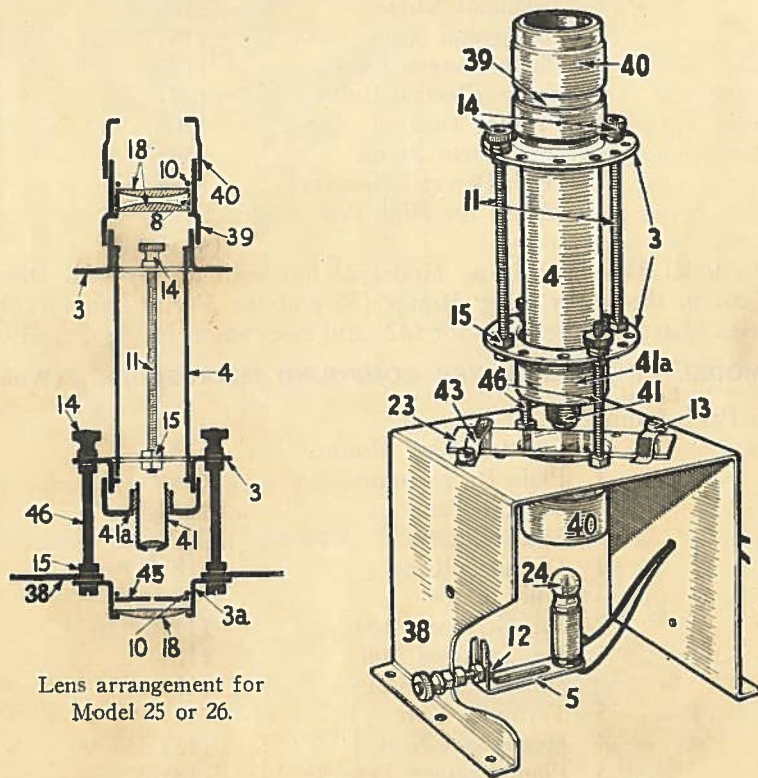

Lens arrangement for
Model 25 or 26.

Model 25.

few turns into its Mount (41a). You now have three assemblies, i.e., the Eyepiece, the mounted Optical Tube and the Objective. Screw the Eyepiece to the upper Ring Mount and the Objective to the lower Ring Mount as shown in the diagram. The next step is to attach a third Ring Mount (3a) to the underside of the Instrument Stand by means of two 2in. Screwed Bolts (46), the free ends of which project upwards, ready to take the optical unit you have just screwed together. Note the

upside-down position for this third Ring Mount as in the picture of Model 23. Now take a few turns with hexagonal nuts (15) on to the free ends of the screwed bolts to support the optical unit, and mount as shown in the picture.

The third Ring Mount on the underside of the Stand takes the large Pinhole Disc (45) inserted from above, and a Plano-Convex Lens (18) from below, with the curved side of the Lens towards the Lamp. Secure both the Pinhole Disc and the Lens with Split Rings. Now mount the Lamp (24) in its Holder (5) in the lower hole of the Stand as shown, and attach the free ends of the wires to the Battery.

NOTE.—When placing slides between the High Power Lens and the top of the Stand, be careful to see that the pin-point of light from below is illuminating the part of the slide you wish to examine. Do not be disappointed if you do not get a clear image at the first attempt. Try screwing the High Power Objective up or down, making sure also that the Lamp is in a directly upright position and directly underneath the Pinhole Disc. Many High Power Microscopes costing guineas do not give better results, so that it is worth a little patience to get things exactly right.

IMPORTANT.—All the parts of the instrument should be centred most carefully. The position of the large Pinhole Disc (45) is most important and it should be moved until the best position is obtained.

MODEL 26.—HIGH POWER COMPOUND MICROSCOPE.
(With Reflector.)

Parts required:—

- | | | |
|---|---------------------------------|------|
| 2 | Screwed Ring Mounts | (3) |
| 1 | Plain Ring Mount | (3a) |
| 1 | Optical Tube | (4) |
| 1 | Lampholder | (5) |
| 1 | Distance Ring | (8) |
| 3 | Split Rings | (10) |
| 2 | 3in. Screwed Rods | (11) |
| 1 | 1in. Screwed Bolt | (12) |
| 2 | $\frac{3}{4}$ in. Screwed Bolts | (13) |

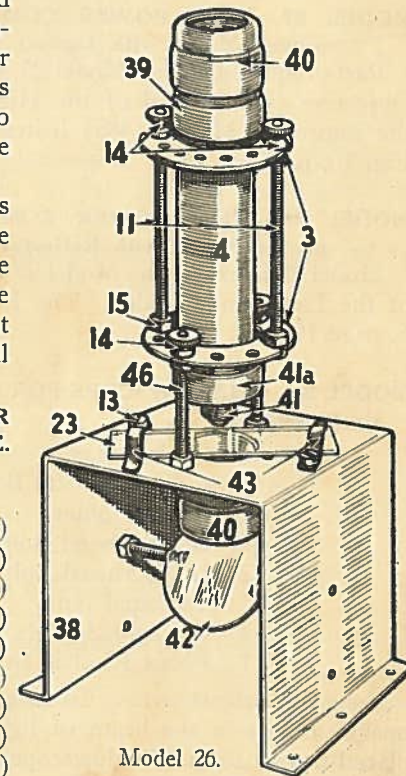

Model 26.

5	Terminal Nuts	(14)
13	Hexagonal Nuts	(15)
3	Plano-Convex Lenses	(18)
1	Focus Electric Bulb	(24)
1	Instrument Stand	(38)
1	Tubular Mount	(39)
1	Cap for Tubular Mount	(40)
1	High Power Objective	(41)
1	Cap for High Power Objective	(41a)
1	Reflector	(42)
2	Spring Clips	(43)
1	Large Pinhole Disc	(45)
2	2in. Screwed Bolts	(46)

Model 26 is exactly as Model 25 but a Reflector (42) is used instead of the Focus Lamp (24), the Reflector being mounted as in Fig. 6, page 19.

MODEL 27.—HIGH POWER COMPOUND MICROSCOPE. (Improved Model with Lamp.)

Parts required as for Model 25, but the improved High Power Objective (48) instead of the High Power Objective (41) and the improved Mount (48a) instead of the Mount (41a). See Fig. 10, p. 22.

MODEL 28.—HIGH POWER COMPOUND MICROSCOPE. (Improved Model with Reflector.)

Model 28 is exactly as Model 27 but with Reflector (42) instead of the Lamp and Holder. The Reflector is mounted as in Fig. 6, page 19.

MODEL 29.—SHADOWSCOPE FOR DARK ROOM.

Parts required:—

1	Optical Box	(1)
1	Lid for Optical Box	(2)
1	Lamp Holder	(5)
1	1in. Screwed Bolt	(12)
2	½in. Screwed Bolts	(13)
1	Terminal Nut	(14)
4	Hexagonal Nuts	(15)
1	Focus Electric Bulb	(24)

Construct as shown. To use the Shadowscope, place an opaque object in the beam of light. A small object should be placed nearer to the Shadowscope than a large one. All manner

of objects may be used. Figures such as animal heads may be cut from card or sheet metal. Mechanical toys may be shown working, Japanese flowers expanding, insects, flowers, leaves, etc., may be shown in silhouette. Shadowscopes may be used for examining the form of screw threads, projecting geometrical figures, lines of magnetic force, jets or drops of water, etc. Projections of moving objects such as a working model of a steam engine are particularly interesting.

Model 29 may be used in the position shown to project shadows on the ceiling or it may be turned on its side to project shadows on the wall.

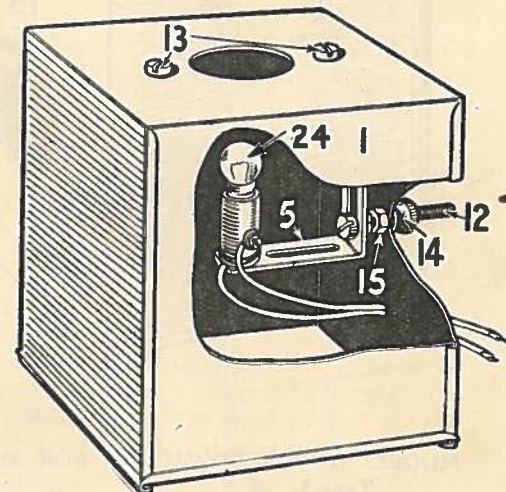

Model 29.

More information on Shadowscopes is given in the article, Experimental Optics No. 3, in the July issue of the *Construmag*, page 82.

MODEL 30.—DAYLIGHT SHADOWSCOPE. (Horizontal Projection.)

Parts required:—

1	Optical Box	(1)
1	Lampholder	(5)
1	3in. Screwed Rod	(11)
2	½in. Screwed Bolts	(13)
1	Terminal Nut	(14)
4	Hexagonal Nuts	(15)
1	Frosted Glass Screen	(22)
1	Focus Electric Bulb	(24)

Construct as shown with a Frosted Glass Screen (22) in the back of the Optical Box (1).

Model 30 is for use with small objects which are held between the Lamp and the large central hole of the Optical Box so that the image of the object is projected on the Frosted Glass Plate at the back of the Box. Lace, paper cuttings, toy animals, small leaves, flowers, parts of a watch, etc., are suitable objects.

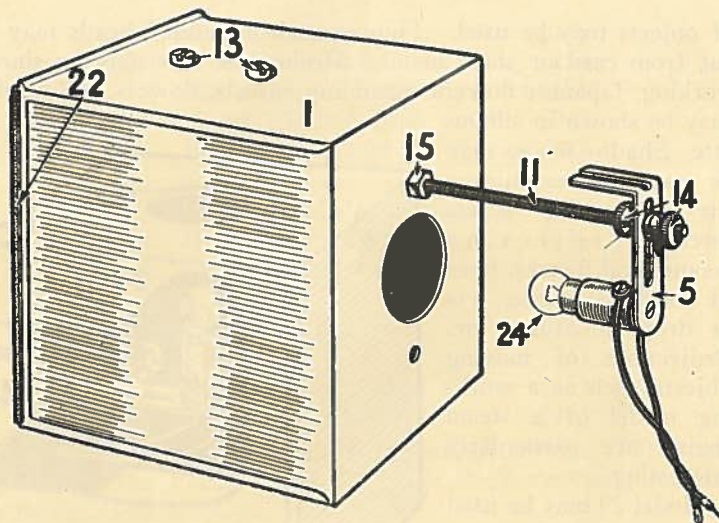

Model 30.

MODEL 31.—SHADOWSCOPE FOR DARK ROOM. (Reflection Type.)

Parts required:—

As for Model 29 with the addition of the parts required for Model 93. Two of the Terminal Nuts (14) and $\frac{1}{4}$ in. Screwed Bolts (13) will not be required.

Place Model 29 so that the large central hole of the Optical Box (1) is in the upper surface of the Box. Place Model 93, with the Mirror (20) reversed, so that its Ring Mount (3a) projects through the hole of the Box.

When in use, the Mirror (20) reflects the beam of light horizontally so that it may be thrown on a wall or screen.

Model 93 may also be mounted above the Optical Box (1)

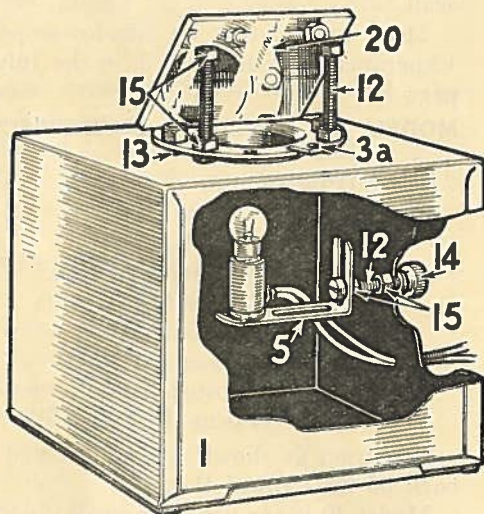

Model 31.

using 1in. Screwed Bolts (12) and Hexagonal Nuts (15). In this case the object may be placed on the Optical Box between it and Model 29. This enables living objects such as minnows, water beetles, pond life, etc., to be projected on a wall, instead of on the ceiling.

MODEL 32.—SHADOWSCOPE WITH GLASS STAGE.

Parts required:—

1 Optical Box	(1)
1 Lampholder	(5)
2 3in. Screwed Rods	(11)
1 1in. Screwed Bolt	(12)
2 $\frac{1}{4}$ in. Screwed Bolts	(13)
3 Terminal Nuts	(14)
10 Hexagonal Nuts	(15)
1 Glass Plate	(21)
1 Focus Electric Bulb	(24)
1 Instrument Stand	(38)

Mount the Optical Box (1) with the large central hole downwards, to the Instrument Stand (38) by means of two 3in. Screwed Rods (11). Fig. 3B, page 16, will help you to do this. Mount the Focus Lamp (24) in its Holder (5) as shown in the picture and thread the free ends of its wires through the opposite holes of the Instrument Stand ready for attaching to the Battery. Block up the small holes of the Optical Box with $\frac{1}{4}$ in. Screwed Bolts and Terminal Nuts to prevent escape of light.

Instead of replacing the Optical Box Lid (2) use instead the square Glass Plate (21), through which the light from below will shine. This Glass Plate will serve as a convenient "stage" on which to rest articles or objects which you wish to view in silhouette on the ceiling. Insects in a "live box," minnows or water beetles in a glass dish, and various other living things of a suitable size can thus be seen greatly enlarged on the ceiling affording endless interest in the study of their movements.

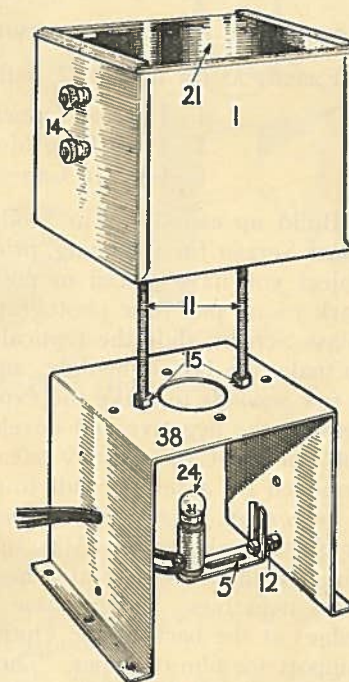

Model 32.

MODEL 33.—DAYLIGHT SHADOWSCOPE. (Vertical Type.)

Build this exactly as Model 32, but use the Frosted Glass Screen (22) instead of the Glass Plate. If now you hold the objects to be projected between the Instrument Stand and the Optical Box and look down on the Frosted Screen, you will see them projected thereon as silhouette "pictures." *For small objects only.*

MODEL 34.—PHOTO-SHADOWGRAPH.

Exactly as for Model 32, with the addition of the following:—

1 Lid for Optical Box	(2)
1 Plain Ring Mount	(3a)
1 Camera Cap	(6)

Build up exactly as in Model 33 above, but use the Frosted Glass Screen for focussing, prior to taking the photograph of the object you have placed in position over the light. Then, in a dark room, put your photographic plate in place of the Frosted Glass Screen, slide the Optical Box Lid (2) firmly into position to make the box light-tight, and switch on the Focus Lamp for a few seconds to make the exposure. Then switch off the lamp, remove the negative and develop and fix in the usual way. Or the Camera Cap (6) may be used to screen from the light and removed for a few seconds to make the exposure.

Important. Use of Cut Film or Photographic Paper. Cut film or photographic paper (3½ in. square), (the latter to take the image direct without the use of a negative), may be utilised instead of glass negatives. In this case rest the Glass Plate (21) on the ledges at the back of the Optical Box in order to provide a flat support for film or paper. Then replace the Optical Box Lid (2) before taking the photograph. It is necessary to place the Frosted Glass Screen (22) on top of the film or paper to keep it flat.

MODEL 35.—SHADOWSCOPE FOR DARK ROOM. (Downward-Throw for Small Objects.)

Parts required:—

1 Optical Box	(1)
1 Lid for Optical Box	(2)
1 Lampholder	(5)
2 3in. Screwed Rods	(11)
1 1in. Screwed Bolt	(12)
1 Terminal Nut	(14)

10 Hexagonal Nuts	(15)
1 Focus Electric Bulb	(24)
1 Instrument Stand	(38)

Mount the Optical Box (1) and the Instrument Stand (38) exactly as in Models 32, 33, and 34, but instead of mounting the Lamp in the side of the Stand, mount it inside the Optical Box as in Fig. 7, page 19. Then close the lid of the Optical Box, and you will have the light from the lamp shining downwards through the central hole of the Optical Box.

Place a sheet of white paper or white card on the table underneath the Instrument Stand (38), and project the silhouette image downwards by placing the slide or other object on top of the Instrument Stand.

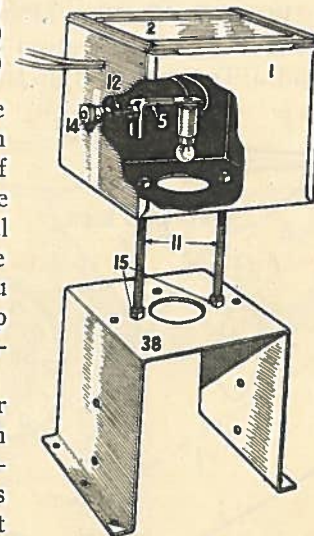

Model 35.

MODEL 36.—PHOTO-SHADOWGRAPH. (Downward-Throw.)

Parts required:—

The same as for Model 35 with the addition of the following—

1 Ring Mount	(3 or 3a)
1 Camera Cap	(6)

Construct exactly as Model 35, but use a piece of photographic paper instead of the white paper or card. The Camera Cap (6) may be used on a Ring Mount (3) in the large central hole of the Optical Box, in order to make exposures.

Use in a dark room, exposing by means of a few seconds' illumination from the lamp in the Optical Box, and then develop in the usual way.

MODEL 37.—CAMERA OBSCURA. (Toy Model.)

Parts required:—

1 Optical Box	(1)
1 Lid for Optical Box	(2)
1 Ring Mount	(3 or 3a)
1 Split Ring	(10)
1 ½in. Screwed Bolt	(13)
1 Terminal Nut	(14)
1 Bi-Convex Lens	(17)
1 Piece of White Card (made to instructions)	

First attach a Ring Mount (3) or (3a) to the lower small hole at the side of the Optical Box by means of a $\frac{1}{2}$ in. Screwed Bolt and a Terminal Nut as shown in the picture. Notice that this

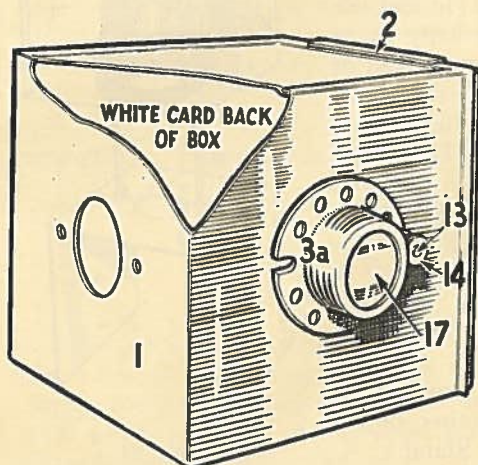

Model 37.

brings the small central hole of the Box directly in the centre of the Ring Mount. Now insert the Bi-Convex Lens (17) into the Ring Mount as in Fig. 1, p. 15, securing with a Split Ring as usual. Cut a piece of white card the size of the side-wall of the Optical Box and insert into the Box so that it is opposite the mounted lens. The picture makes this clear. Then slide on the Optical Box Lid (2).

If you now hold the lens towards any well-lighted object such as a tree, a building, a window, etc., and look sideways at the white paper or card through the large central hole of the Box, you will see an image projected on the white surface. Though this is a toy model it well illustrates the principle of the Camera Obscura which projects a focussed image through a small aperture in an otherwise dark room or box.

MODEL 38.—PINHOLE CAMERA. (Box Type.)

Parts required:—

1 Optical Box	(1)
1 Lid for Optical Box	(2)
1 Ring Mount	(3 or 3a)
1 Camera Cap	(6) or (6a)
1 Small Pinhole Disc	(9)
1 Split Ring	(10)
4 $\frac{1}{2}$ in. Screwed Bolts	(13)
4 Terminal Nuts	(14)
1 Frosted Glass Plate	(22)

Construct Model 38 as shown. The small Pinhole Disc (9) is fixed in the Ring Mount (3 or 3a) by means of a Split Ring (10).

To take a photograph, place the Frosted Screen (22) on the

ledges at the back of the Box and then point the pinhole towards a well-lighted window. You will see the image of the window on the Frosted Screen. Mark the distance from the window at which the image is of suitable size. Now put the Camera Cap (6) or (6a) over the end of the Ring Mount so as to screen the pinhole, and remove the Camera to a dark room so that you

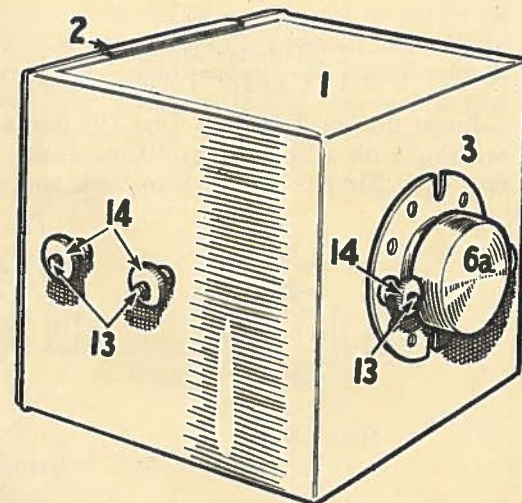

Model 38.

can substitute a photographic plate for the Frosted Screen. Slide in the Lid of the Optical Box (2) to make the camera light-tight and take it back to the spot previously marked. Remove the Camera Cap in order to make the exposure. Note that a much longer exposure is needed with a pinhole than with a lens (a full minute or more) and that the camera must not be moved until after the cap is replaced. There is no focussing required with a pinhole, and though such a camera is only a toy, it is interesting to note that traffic or people may pass in front of it during exposure without appearing on the photograph, which will only show stationary objects, such as a building.

One may also observe eclipses of the sun or moon on the Frosted Screen without injuring the eyes, or try other experiments both with the screen or photographically. Read the article on Pinhole Photograph in the July issue of the *Construmag*, p. 128.

MODEL 39.—PINHOLE CAMERA. (Midget Type.)

Parts required:—

2 Screwed Ring Mounts	(3)
2 Camera Caps	(6)
1 Small Pinhole Disc	(9)
2 Split Rings	(10)
2 $\frac{1}{2}$ in. Screwed Bolts	(13)
2 Terminal Nuts	(14)

- | | | |
|---|-----------------------|------|
| 1 | Frosted Disc | (26) |
| 2 | Tubular Mounts | (39) |
| 1 | Cap for Tubular Mount | (40) |

Insert the small Pinhole Disc (9) into a Tubular Mount (39) securing with a Split Ring (10) as usual. Next fasten together two Ring Mounts (3) back to back and screw on the Tubular

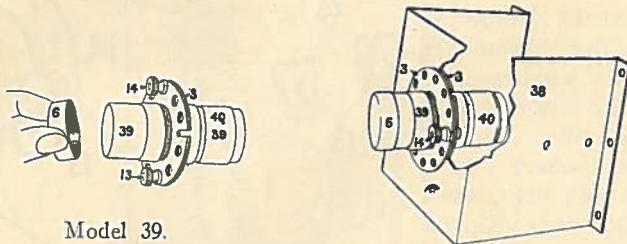

Model 39.

Method of mounting
Model 39.

Mount containing the Pinhole Disc. On the other Ring Mount screw on a Tubular Mount containing the Frosted Disc (26) for focussing the image. Or the Frosted Disc may be inserted in the Ring Mount itself as in Model 43. To give stability and to prevent movement during exposure Midget Type and Button-Hole-Picture Cameras may be mounted on the Instrument Stand (38) as shown here, the Ring Mounts being first affixed, back to back, to the Stand.

MODEL 40.—PINHOLE CAMERA FOR TRANSPARENT OBJECTS.

Parts required:—

- | | | |
|----|---------------------|-----------|
| 1 | Optical Box | (1) |
| 1 | Ring Mount | (3 or 3a) |
| 1 | Lampholder | (5) |
| 1 | Small Pinhole Disc | (9) |
| 1 | Split Ring | (10) |
| 2 | 3in. Screwed Rods | (11) |
| 1 | 1in. Screwed Bolt | (12) |
| 2 | ½in. Screwed Bolts | (13) |
| 3 | Terminal Nuts | (14) |
| 10 | Hexagonal Nuts | (15) |
| 1 | Frosted Glass Plate | (22) |
| 1 | Focus Electric Bulb | (24) |
| 1 | Instrument Stand | (38) |

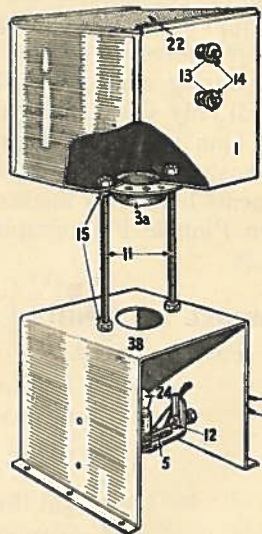

Model 40.

Mount the Pinhole Camera Model 38, to the Instrument Stand (38) by means of two 3in. Screwed Rods (11), exactly as in Model 32, but having the Focus Lamp (24) mounted through the lower small hole at the side of the stand instead of the central one. Small opaque objects, transparencies or slides, may then be seen on the Frosted Glass Screen (22) placed on top of this model, and afterwards photographed by means of the electric light below them.

MODEL 41.—LENS CAMERA. (Short Range Box Type.)

Parts required:—

- | | | |
|---|-----------------------------------|------|
| 1 | Optical Box | (1) |
| 1 | Lid for Optical Box | (2) |
| 1 | Screwed Ring Mount | (3) |
| 1 | Camera Cap | (6) |
| 1 | Split Ring | (10) |
| 4 | ½in. Screwed Bolts | (13) |
| 4 | Terminal Nuts | (14) |
| 1 | Bi-Convex Lens | (17) |
| 1 | Frosted Glass Screen | (22) |
| 1 | Stop for Lens (37a), (44) or (45) | |

Model 41 is constructed as Model 38, but a Bi-Convex Lens (17) is substituted for the Small Pinhole Disc (9). A Stop for the Lens (37a) or (45) is fixed on the side of the Ring Mount (3) not occupied by the Lens. The Lens may be fixed in either of two positions.

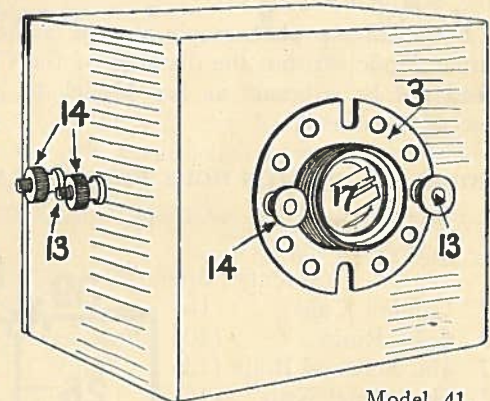

Model 41.

To take a photograph proceed as follows. Place the Frosted Glass Screen (22) in the back of the Optical Box (1). Place the Camera with the Camera Cap removed at a suitable distance from the object. This will be about seventeen inches and twenty-one inches for the outer and inner positions of the Lens (see p. 17). The image on the Frosted Glass Screen should now be clear, and by moving the Camera may be brought into a suitable position. Mark the position of the Camera and then remove it to a dark room and load with a 3½in. x 3½in. photographic plate. The sensitive side of the plate should touch the ledges at the back

of the Optical Box. Slide the Lid of the Optical Box into place and cover the Ring Mount (3) with the Camera Cap (6). The Camera Cap should be capable of easy removal. Replace the Camera in position in front of the object and expose, develop, etc., in the ordinary way.

For further information see the Photographic Articles in the *Construmag*, especially "The Lens Camera," p. 149, August, 1933. Another article on "Photography with a Box Camera" appeared on p. 4 of the *Construmag*, February, 1933.

MODEL 42.—LENS CAMERA. (Long Range Box Type.) See p. 17.

Parts required as for Model 41. and in addition

- 1 Plain Ring Mount (3a)

Model 42 is similar to Model 41, but the Screwed Ring Mount (3) is fixed *inside* the Optical Box (1) and the Plain Ring Mount (3a) is fixed outside the Optical Box. There are two positions in which the Bi-Convex Lens (17) may be fixed in the Screwed Ring Mount (3). The innermost Lens position is for very distant objects. The other position is for objects at a distance of about fifty-six inches.

For taking a photograph use the same method as described under Model 41, but the distance of the Camera from the object need not be so exact as for Model 41, providing the distance exceeds six feet.

MODEL 43.—BUTTON-HOLE PICTURE CAMERA.

Parts required:—

- | | | | |
|---|---------------------------------|---------|-------|
| 2 | Screwed Ring | Mounts | 3() |
| 2 | Camera Caps | | (6) |
| 2 | Split Rings | | (10) |
| 2 | $\frac{1}{2}$ in. Screwed Bolts | | (13) |
| 2 | Hexagonal Nuts | | (15) |
| 1 | Plano-Convex | Lens | (18) |
| 1 | Frosted Disc | | (26) |
| 2 | Tubular Mounts | | (39) |
| 2 | Caps for Tubular | Mounts | (40) |
| 1 | Lens Stop | (44) or | (37a) |

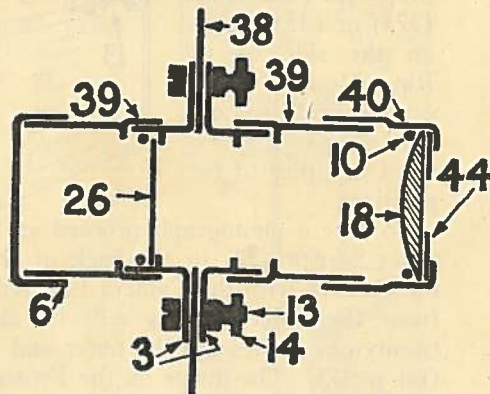

Model 43.

First place a Lens Stop (44) into a Tubular Mount Cap (40). Then insert a Plano-Convex Lens (18) with the curved side inwards and secure with a Split Ring (10). Put the Camera

Cap (6) on to the Tubular Mount (39) and screw to the Ring Mount as shown. Model 43 may be mounted to the Instrument Stand as in Model 39 and use the back Ring Mount (3) to contain the Frosted Disc upon which you can focus the image. A second Tubular Mount and Cap must then be affixed to the back Ring Mount as shown in Model 39. Read the article on "The Midget Camera" in the *Construmag*, September, 1933. See also Model 97.

MODEL 44.—BUTTON-HOLE PICTURE CAMERA. (2 Lens Type.)

Parts required:—

- | | | |
|---|---------------------------------|-------|
| 2 | Screwed Ring Mounts | (3) |
| 2 | Camera Caps | (6) |
| 2 | Split Rings | (10) |
| 2 | $\frac{1}{2}$ in. Screwed Bolts | (13) |
| 2 | Hexagonal Nuts | (15) |
| 2 | Plano-Convex Lenses | (18) |
| 1 | Frosted Disc | (26) |
| 1 | Lens Stop | (37a) |
| 1 | Instrument Stand | (38) |
| 2 | Tubular Mounts | (39) |
| 2 | Caps for Tubular Mounts | (40) |

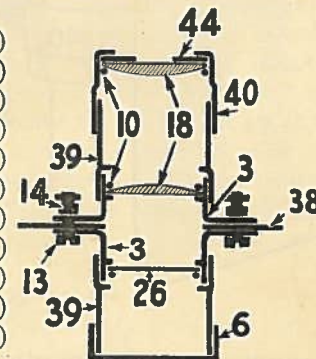

Model 44.

Build up Model 44 in the same way as Model 43, but mount a second Plano-Convex Lens (18) in the Ring Mount (3) to which the Tubular Mount (39) is attached carrying a Lens in the Tubular Mount Cap (40).

MODEL 45.—MICRO-REDUCING CAMERA.

Parts required:—

- | | | |
|---|---------------------------------|-------|
| 2 | Screwed Ring Mounts | (3) |
| 1 | Split Ring | (10) |
| 2 | $\frac{1}{2}$ in. Screwed Bolts | (13) |
| 2 | Terminal Nuts | (14) |
| 1 | Frosted Disc | (26) |
| 1 | Instrument Stand | (38) |
| 1 | Tubular Mount | (39) |
| 1 | Cap for Tubular Mount | (40) |
| 1 | High Power Objective | (41) |
| 1 | Mount for High Power Objective | (41a) |

Attach Ring Mounts (3), one above and one below, to the Instrument Stand (38) as shown, and screw on to the top one the High Power Objective (41) inserted into its Mount (41a), Lens inwards. The Objective should be screwed well down. Now

insert the Frosted Disc (26) into the lower Ring Mount and secure by means of a Split Ring (10). Then screw on to the lower Ring Mount a Tubular Mount (39) with its Cap (40), and the camera is ready for focussing.

This is a highly interesting and novel kind of camera, since it reduces portraits, objects, etc., to a very tiny size so that the photos have to be viewed through a magnifier. A large collection of these tiny photos can thus be contained on one page of an album.

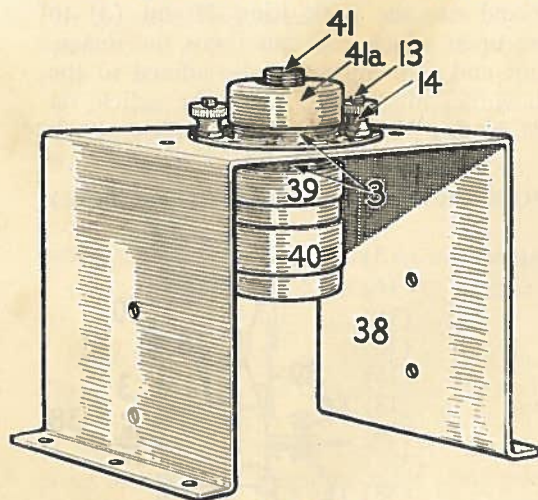

Model 45.

MODEL 46.—MICRO-REDUCING CAMERA. (For Photo Negatives.)

Parts required:—

1 Optical Box	(1)
1 Lid for Optical Box	(2)
2 Screwed Ring Mounts	(3)
1 Camera Cap	(6)
1 Split Ring	(10)
2 3in. Screwed Rods	(11)
2 ½in. Screwed Bolts	(13)
8 Terminal Nuts	(14)
2 Hexagonal Nuts	(15)
1 Frosted Disc	(26)
1 Instrument Stand	(38)
1 High Power Objective	(41)
1 Mount for High Power Objective	(41a)

This is another new and ingenious form of camera for making tiny photo-prints (about an eighth of an inch in diameter) from negatives. The negative is to be placed on the ledges at the top of the Optical Box (1) under the Slide Lid (2) and then exposed directly under an electric light. The construction of this model can be clearly seen from the picture. The High Power

Objective (41) is screwed to the upper of the two Ring Mounts (3) just as in Model 45, and the lower Ring Mount contains the Frosted Disc (26) and accommodates the Camera Cap (6). The distance of the High Power Objective from the Optical Box must be as in the picture, regulated by the number of turns of the nuts on the 3in. Screwed Bolts which are used for mounting.

A Frosted Disc (26) is inserted into the lower Ring Mount (3) and with the negative in position on the ledges of the Optical Box (1), a reduced image of the negative will be seen projected on the Frosted Disc (26). To observe the image, the instrument may be held horizontally with the negative facing a light. Focus by screwing the High Power Objective (41) until the image becomes clear. Then in place of the Frosted Disc (26) insert a Constructions Photographic Disc and place the Camera Cap (6) in position. The instrument should now be placed in such a position that a light falls directly on the negative. The exposure may best be made by illuminating the negative for a second or two according to the density of the negative.

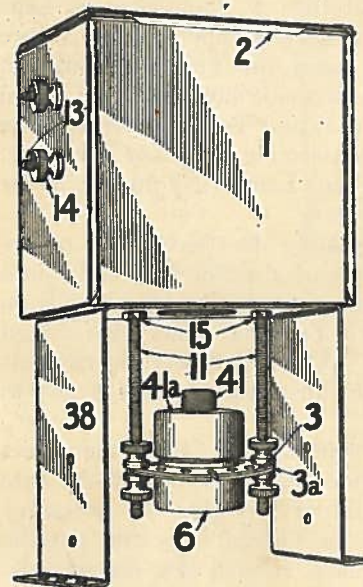

Model 46.

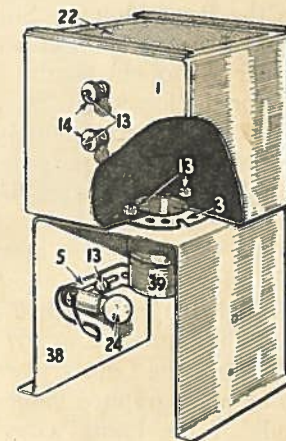

Model 47.

MODEL 47.—PHOTO COPIER AND ENLARGER.

Parts required:—

1 Optical Box	(1)
1 Lid for Optical Box	(2)

1	Ring Mount	(3 or 3a)
1	Lampholder	(5)
1	Camera Cap	(6 or 6a)
1	Split Ring	(10)
5	$\frac{1}{2}$ in. Screwed Bolts	(13)
3	Terminal Nuts	(14)
4	Hexagonal Nuts	(15)
1	Plano-Convex Lens	(18)
1	Frosted Glass Screen	(22)
1	Focus Lamp	(24)
1	Instrument Stand	(38)
1	Tubular Mount	(39)
1	Lens Stop	(44 or 37a)

This Model is best constructed in two sections. First attach a Ring Mount (3) to the Optical Box, using $\frac{1}{2}$ in. Screwed Bolts (13), leaving the free ends projecting. Screw on two extra Hexagonal Nuts (15) for about two-thirds of the way down the Screwed Bolts as shown. Take a Tubular Mount (39) and insert first a Lens Stop (44) and then a Plano-Convex Lens (18). The curved side of the Lens must be uppermost. Secure with a Split Ring (10) and then screw the Tubular Mount on to the Ring Mount. Stop up the two side holes of the Optical Box with two $\frac{1}{2}$ in. Screwed Bolts (13) and Terminal Nuts. The upper part of the picture shows this assembly ready for mounting.

For the lower part, mount the Focus Lamp (24) flush with the side of the Instrument Stand as shown.

This is for the purpose of illuminating the object to be photographed. Now insert the free ends of the Screwed Bolts into the corresponding holes of the Instrument stand and secure from below the Stand by means of two Terminal Nuts (14). You will thus see that the Tubular Mount projects downwards through the large centre hole of the Instrument Stand, ready to take the Camera Cap (6).

To use the Copier place it on a flat surface. Place the object to be photographed immediately under the Lens; attach the bare ends of the Lamp wires of the Battery to give the necessary illumination. Remove the Lid of the Optical Box and put the Frosted Glass Screen (22) in its place, frosted side downwards. You will then see a clear image of the object below. Focus by screwing the Tubular Mount up and down until the image is at its clearest, and then photograph in the usual way. Pictures from books, coins, medals, signatures, fingerprints, postage stamps, flowers, grasses, ladies' watches, butterflies and all manner of flat or flattish objects can be photographed by means of this Model.

When the Frosted Plate (22) has been substituted by a photograph plate and the Lid of the Optical Box placed in position, the exposure is made by connecting up the Lamp to the Battery for the necessary interval.

MODEL 48.—ELECTRIC LAMP PHOTO PRINTER.

Parts required:—

As for Model 30, with the addition of the following:—

1	Ring Mount	(3 or 3a)
1	Camera Cap	(6 or 6a)
3	$\frac{1}{2}$ in. Screwed Bolts	(13)
3	Terminal Nuts	(14)

Construct exactly as Model 30, but place a Ring Mount (3) or (3a) over the large central hole of the Optical Box (1) in order to hold the Camera Cap (6) or (6a). The two small side holes of the Optical Box should be stopped up with $\frac{1}{2}$ in. Screwed Bolts in order to make the Optical Box light-tight.

Take into a dark room and place the negative on the ledges at the back of the Box with the film side uppermost, and place a sheet of photographic printing out paper face downwards on the negative, and then the Glass Plate (21) to keep the paper flat. Replace the Optical Box Lid (2). Now place the Camera Cap on the Ring Mount. To make the exposure connect the Lamp wires to the Battery, and then remove the Camera Cap for a few seconds according to the density of the negative, and develop and fix in the usual manner.

MODEL 49.—ELECTRIC LAMP PHOTO PRINTER. (Improved Type.)

Parts required:—

1	Optical Box	(1)
1	Lid for Optical Box	(2)

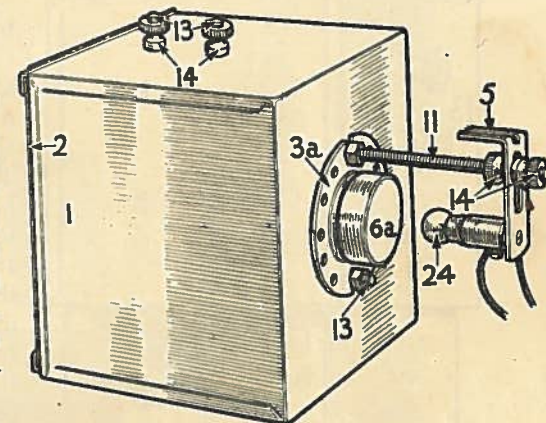

Model 48.

1 Plain Ring Mount	(3 or 3a)
1 Lamp Holder	(5)
1 Camera Cap	(6 or 6a)
1 1in. Screwed Bolt	(12)
4 ½in. Screwed Bolts	(13)
5 Terminal Nuts	(14)
2 Hexagonal Nuts	(15)
1 Glass Plate	(21)
1 Focus Electric Bulb	(24)
1 Instrument Stand	(38)

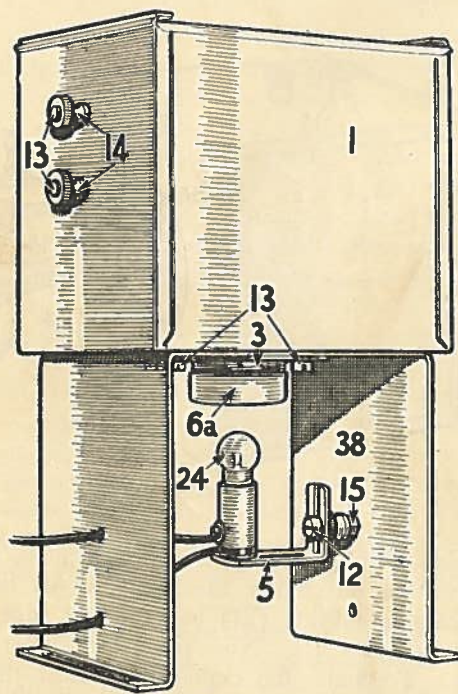

Model 49.

MODEL 50.—RED LAMP FOR DARK ROOM.

Construct exactly as Model 2, but instead of the Lens in the Ring Mount, insert the Red Transparent Disc (27).

Note that it may be advisable to use two or more of these discs to reduce the intensity of the light, especially when using very rapid plates.

MODEL 51.—MAGIC LANTERN.

Parts required:—

1 Optical Box	(1)
1 Lid for Optical Box	(2)
1 Screwed Ring Mount	(3)
1 Plain Ring Mount	(3a)
1 Lamp Holder	(5)
3 Split Rings	(10)
3 1in. Screwed Bolts	(12)
3 Terminal Nuts	(14)
6 Hexagonal Nuts	(15)
3 Plano-Convex Lenses	(18)
1 Bi-Convex Electric Bulb	(25)
1 Tubular Mount	(39)
1 Cap for Tubular Mount	(40)

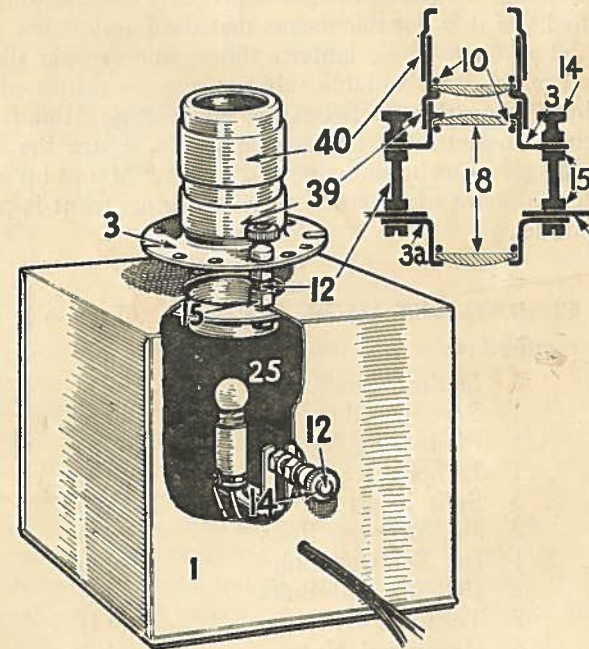

Model 51.

Fix a Ring Mount (3) *inside* the Optical Box (1) using 1in. Screwed Bolts (12) so that the free ends project outwards ready for taking the upper mounting. Insert into the Ring Mount a Plano-Convex Lens (18) with the curved side of the Lens

towards the inside of the Box. This acts as a condenser. Now mount the Bi-Convex Lamp (25) in its Lampholder in the central hole at the side of the Optical Box so that the Lamp is directly underneath and exactly central with the Lens. Thread the free ends of the wires through the remaining hole ready for attaching to the Battery. Now fix a Ring Mount to the free ends of the projecting Screwed Bolts at the distance shown and insert into it a Plano-Convex Lens (curved side upwards). Place a third Plano-Convex Lens (curved side downwards) in the Tubular Mount (39) separated from the Lens already there by a Distance Ring (8). (See diagram.) Place the Tubular Mount Cap (40) over the Tubular Mount and screw on to the upper Ring Mount as shown in the picture.

Attach Lamp wires to the Battery by means of the Battery Clips (7) and project the light on to a wall or screen in a dark room. See that the patch of light is properly circular and equally illuminated. If it is not this means that the Lamp is not properly central. Toy strip magic lantern slides, microscopic slides, toy films, and many other suitable subjects may be projected by this Model by holding them between the upper Ring Mount and the large central hole of the Optical Box. To secure the sharpest possible image, focus by screwing the Tubular Mount up or down. An endless amount of entertainment and experiment is provided by this Model.

MODEL 52.—DAYLIGHT MAGIC LANTERN. (Type A.)

Parts required:—

1 Optical Box	(1)
1 Screwed Ring Mount	(3)
1 Plain Ring Mount	(3a)
1 Lampholder	(5)
3 Split Rings	(10)
2 3in. Screwed Rods	(11)
1 1in. Screwed Bolt	(12)
2 ½in. Screwed Bolts	(13)
7 Terminal Nuts	(14)
6 Hexagonal Nuts	(15)
3 Plano-Convex Lenses	(18)
1 Frosted Glass Screen	(22)
1 Bi-Convex Electric Bulb	(25)
1 Instrument Stand	(38)
1 Tubular Mount	(39)
1 Cap for Tubular Mount	(40)

Fix a Ring Mount (3) to the Optical Box using 3in. Screwed Rods (11) instead of the ½in. Screwed Bolts, leaving the free ends of the rods projecting outwards ready for mounting the Optical Box to the Instrument Stand (38). Place one Plano-Convex Lens into the Ring Mount with the curved side upwards,

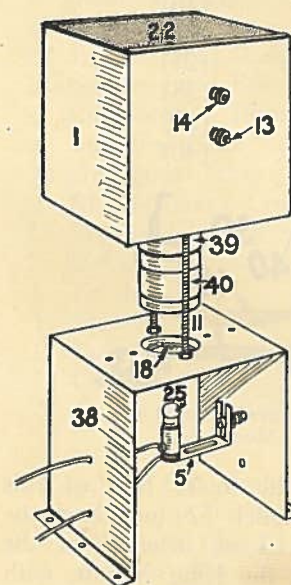

Model 52.

(40) with the curved side downwards. Secure the Lenses by means of Split Rings (10), push the Cap on to the Mount and screw on to the Ring Mount. (See Model 80.) For the lower part of this Model fix a Ring Mount (3a) to the under side of the large central hole of the Instrument Stand (38) and insert into it another Plano-Convex Lens with the curved side upwards, i.e., the flat side towards the Lamp. Mount the Bi-Convex Lamp (25) as shown, and then fix the Instrument Stand to the Optical Box by means of the free ends of the Screwed Bolts, securing firmly with nuts. Focus by sliding the Tubular Mount Cap up or down. To obtain a rather larger magnification when viewing small objects, mount the Optical Box a little closer to the Instrument Stand and use the Lens positions as in Model 51.

Use the same kinds of subjects as for the Magic Lantern, placing the slides, etc., on top of the Instrument Stand and projecting the image upwards so that it appears on the Frosted Glass Screen (22) which you will place on the ledges of the Optical Box with the Optical Box Lid removed. Focus until the image is sharpest by screwing the Tubular Mount up or down. Many interesting demonstrations may be given with this "Daylight" type which, of course, gives even better results in a dark room.

MODEL 53.—DAYLIGHT MAGIC LANTERN. (Type B.)

Parts required:—

1 Optical Box	(1)
1 Screwed Ring Mount	(3)
1 Plain Ring Mount	(3a)

- | | | |
|----|---------------------------------|------|
| 1 | Lampholder | (5) |
| 3 | Split Rings | (10) |
| 2 | 3in. Screwed Rods | (11) |
| 3 | 1in. Screwed Bolts | (12) |
| 2 | $\frac{1}{2}$ in. Screwed Bolts | (13) |
| 9 | Terminal Nuts | (14) |
| 10 | Hexagonal Nuts | (15) |
| 3 | Plano-Convex Lenses | (18) |
| 1 | Frosted Glass Screen | (22) |
| 1 | Bi-Convex Electric Bulb | (25) |
| 1 | Instrument Stand | (38) |
| 1 | Tubular Mount | (39) |
| 1 | Cap for Tubular Mount | (40) |

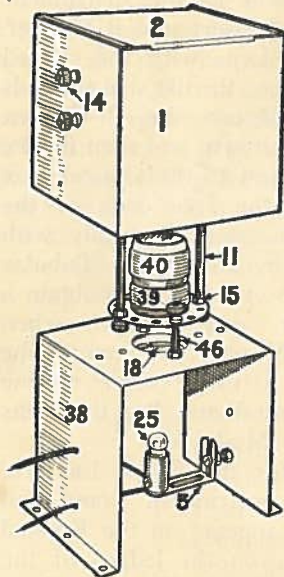

Model 53.

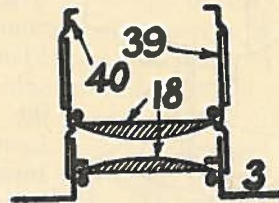

Lens arrangement for Model 53.

Construct the lower half of this Model as Model 52 including the Plano-Convex Lens inserted in the lower end of the Ring Mount, with the flat face of the Lens towards the Lamp. Before mounting the Optical Box on the free ends of the 3in. Rods fix a Ring Mount (3) with Tubular Mount (39) attached in the position shown in the drawing—that is, midway between the Instrument Stand (38) and the Optical Box (1). It will

be noticed in this Model that the Ring Mount is not attached to the Optical Box directly but by the 3in. Rods. The Lenses are arranged as follows—one Plano-Convex (18) is inserted into the Ring Mount, curved side upwards. The other Plano-Convex is placed in the Tubular Mount with the curved side downwards. The Lenses are arranged with their curved surfaces facing one another.

Use the Model as No. 52. It will be interesting to make a comparison between Models 52 and 53 and note which of them gives better results.

MODEL 54.—LOW POWER PROJECTION MICROSCOPE.

Parts required:—

- | | | |
|----|---------------------------------|------|
| 1 | Optical Box | (1) |
| 1 | Screwed Ring Mount | (3) |
| 1 | Plain Ring Mount | (3a) |
| 1 | Lampholder | (5) |
| 1 | Distance Ring | (8) |
| 2 | Split Rings | (10) |
| 2 | 3in. Screwed Rods | (11) |
| 1 | 1in. Screwed Bolt | (12) |
| 2 | $\frac{1}{2}$ in. Screwed Bolts | (13) |
| 9 | Terminal Nuts | (14) |
| 10 | Hexagonal Nuts | (15) |
| 2 | Plano-Convex Lenses | (18) |
| 1 | Frosted Glass Screen | (22) |
| 1 | Bi-Convex Electric Bulb | (25) |
| 1 | Frosted Disc | (26) |
| 1 | Instrument Stand | (38) |
| 1 | Tubular Mount | (39) |
| 1 | Cap for Tubular Mount | (40) |
| 2 | 2in. Screwed Bolts | (46) |

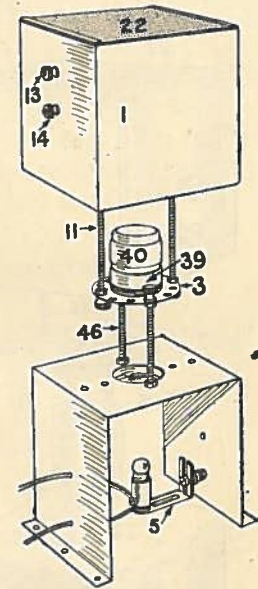

Model 54.

Construct this Model as follows:—the central Ring Mount (3) is fixed to the Instrument Stand (38) by means of two 2in. Screwed Bolts (46) and the necessary Nuts. The Optical Box (1) mounted above the Ring Mount by two 3in. Screwed Rods (11). In the Tubular Mount place a Distance Ring (8) and then insert a Plano-Convex Lens (18) with the curved side downwards. In the Ring Mount attached to the underside of the Instrument Stand place another Plano-Convex Lens and secure with a Split Ring.

Ensure that the Lamp is fixed centrally with the aperture in the Instrument Stand, and that the Model is adjusted to stand vertically.

Place the object to be viewed on a Glass Slide across the aperture in the Instrument Stand and light the Lamp. Focus the image on the Frosted Glass Screen (22).

When viewing objects which are thin and very transparent it will be found advisable to place a Frosted Disc (26) in the Ring Mount below the Instrument Stand.

MODEL 55.—MEDIUM POWER PROJECTION MICROSCOPE.

Parts required:—

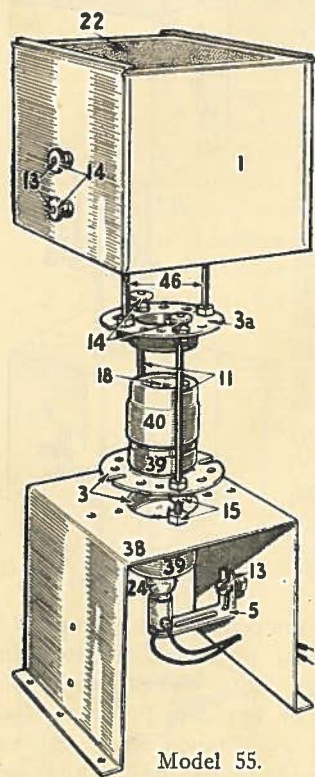

Model 55.

- | | | |
|----|-------------------------|------|
| 1 | Optical Box | (1) |
| 2 | Screwed Ring Mounts | (3) |
| 1 | Plain Ring Mount | (3a) |
| 1 | Lampholder | (5) |
| 1 | Distance Ring | (8) |
| 3 | Split Rings | (10) |
| 2 | 3in. Screwed Rods | (11) |
| 1 | 1in. Screwed Bolt | (12) |
| 2 | ½in. Screwed Bolts | (13) |
| 7 | Terminal Nuts | (14) |
| 16 | Hexagonal Nuts | (15) |
| 3 | Plano-Convex Lenses | (18) |
| 1 | Frosted Glass Screen | (22) |
| 1 | Bi-Convex Electric Bulb | (25) |
| 1 | Instrument Stand | (38) |
| 2 | Tubular Mounts | (39) |
| 2 | Caps for Tubular | |
| | Mounts | (40) |
| 2 | 2in. Screwed Bolts | (46) |

When constructing this Model it will be helpful to refer to Model 54. In this case, however, 3in. Screwed Rods (11) are attached to the Instrument Stand and the upper Ring Mount (3) is secured to the Optical Box (1) by two 2in. Screwed Bolts (46)

instead of the other way round as in the previous Model. A Plano-Convex Lens is inserted into the Tubular Mount Cap and another Plano-Convex Lens into the Tubular Mount, the curved faces of the Lenses being arranged to face one another. It will be best to screw on the Tubular Mount and Cap to the lower Ring Mount before the upper Plain Ring Mount (3a) is placed in position, as the available space is small. To the underside of the Instrument Stand (38) fix a Ring Mount and to this attach a Tubular Mount to which has been fitted a Plano-Convex Lens with the curved side facing downwards.

To secure greater magnification the position of the Lenses may be altered in the following way. The Lens in the central Tubular Mount is lowered into the Ring Mount and the Lens in the Tubular Mount Cap is placed on a Distance Ring in the Tubular Mount.

Read the article on "Micro-Photograph in the Home," p. 15 of the February issue of the *Construmag*.

To use, place the microscope slide, or other object to be viewed, between the Instrument Stand and the lower Ring Mount, light the lamp, and focus on to the Frosted Glass Screen (22) which you can rest on the ledges at the top of the Optical Box. Insects' legs, all kinds of small objects mounted between Glass Slides (23), and many other small objects may be seen enlarged in a circle of light on the Frosted Screen, which should be placed frosted side downwards.

MODEL 56.—HIGH POWER PROJECTION MICROSCOPE.

Parts required:—

- | | | |
|----|-------------------------|-------|
| 1 | Optical Box | (1) |
| 2 | Screwed Ring Mounts | (3) |
| 1 | Lampholder | (5) |
| 1 | Distance Ring | (8) |
| 1 | Split Ring | (10) |
| 2 | 3in. Screwed Rods | (11) |
| 2 | 2in. Screwed Bolts | (46) |
| 1 | 1in. Screwed Bolt | (12) |
| 2 | ½in. Screwed Bolts | (13) |
| 9 | Terminal Nuts | (14) |
| 10 | Hexagonal Nuts | (15) |
| 2 | Plano-Convex Lenses | (18) |
| 1 | Frosted Glass Screen | (22) |
| 1 | Bi-Convex Electric Bulb | (25) |
| 1 | Instrument Stand | (38) |
| 1 | Tubular Mount | (39) |
| 1 | Cap for Tubular Mount | (40) |
| 1 | High Power Objective | (41) |
| 1 | Mount for High Power | |
| | Objective | (41a) |

Construct Model 56 as shown. A Ring Mount (3) is fixed to the under side of the Instrument Stand (38). To this Ring Mount screw a Tubular Mount containing two Plano-Convex Lenses (18) separated by a Distance Ring (8) and fixed by a Split Ring (10). This arrangement acts as a Condenser and focusses the light from the Bi-Convex Electric Bulb (25) on the object under observation. The Lamp should be adjusted carefully into a position which gives the best results.

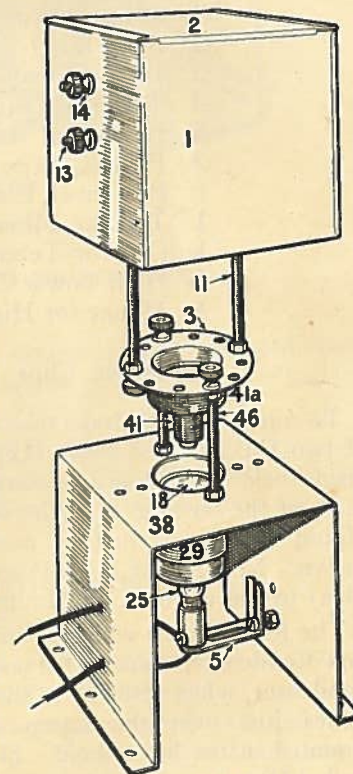

Model 56.

This instrument is useful for projecting images of very small objects such as cheese mites, pollen, etc., which can hardly be seen with the naked eye. Focus the images until they become sharp by screwing the High Power Objective up or down.

MODEL 57.—HIGH POWER PROJECTION MICROSCOPE. (Dark Room Type.)

Parts required:—

- | | |
|----------------------------------|-------|
| 1 Optical Box | (1) |
| 2 Screwed Ring Mounts | (3) |
| 1 Lampholder | (5) |
| 1 Distance Ring | (8) |
| 1 Split Ring | (10) |
| 3 lin. Screwed Bolts | (12) |
| 3 Terminal Nuts | (14) |
| 6 Hexagonal Nuts | (15) |
| 2 Plano-Convex Lenses | (18) |
| 1 Bi-Convex Electric Bulb | (25) |
| 1 Tubular Mount | (39) |
| 1 Cap for Tubular Mount | (40) |
| 1 High Power Objective | (41) |
| 1 Mount for High Power Objective | (41a) |
| 2 Spring Clips | (43) |

To construct this Model take the Optical Box (1) and by means of two lin. Screwed Bolts (12) attach a Ring Mount (3) to the inside below the aperture, securing with two Hexagonal Nuts (15) on the outside. On the outside of the Box a second Ring Mount (3) is attached by means of Hexagonal Nuts (15) as shown. Now fix the High Power Objective and Mount (41) and (41a) to the upper Ring Mount as shown.

The Ring Mount which is inside the box accommodates a two-lens Condenser, constructed as described for Model 56. This Condenser, when screwed to the Ring Mount in the Optical Box, comes just over the Lamp and the Lampholder should be mounted in the lower hole. For this Model use the Bi-Convex Bulb (24).

This is for minute microscopic objects only, such as mites, mosquitos, botanical sections, etc. Hold the slide between the High Power Lens and the top of the Optical Box, or secure by means of the Spring Clips (43), and project on to a white screen or sheet of white card in a dark room. Be sure to see that the

Lamp is exactly central to the Condenser above it, and focus by screwing the High Power Objective up or down until the image is at its clearest in the circle of light. A screen distance of two to four feet is suitable.

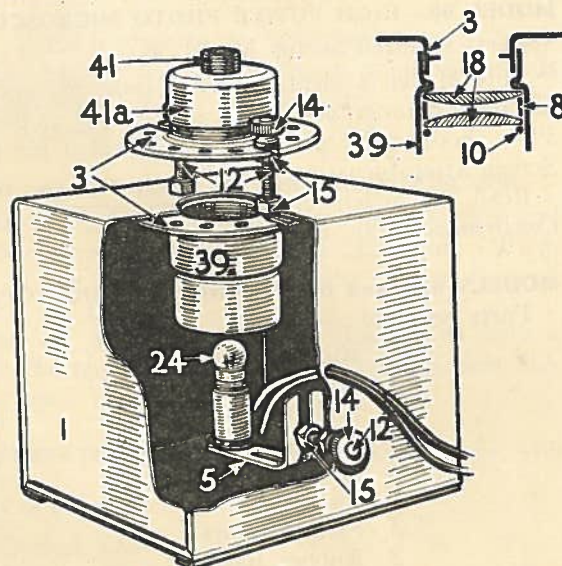

Model 57.

MODEL 58.—LOW POWER PHOTO MICROSCOPE.

Parts required as for Model 54.

Construct as Model 54, but after focussing on the Frosted Glass Screen (22), substitute a Construments Photographic Plate or Paper.

NOTE.—In this and the next two Models (59 and 60), you may use the Camera Cap (6a) after fixing a Plain Ring Mount (3a) to the under side of the Optical Box (1) to accommodate it.

MODEL 59.—MEDIUM POWER PHOTO MICROSCOPE.

Parts required as for Model 55.

The construction of this Model is exactly the same as that of Model 55, but it is used for photographic purposes.

Place the specimen that you wish to photograph on a slide and secure with the Spring Clips (43). Focus until a sharp image is obtained. The Model is then removed to a dark room, and a photographic plate is substituted for the Frosted Glass Plate (22). The Optical Box Lid (2) should then be placed in position above the photographic plate. The exposure is then made by connecting up the lamp for a few seconds, the time depending on the density of the subject under examination.

MODEL 60.—HIGH POWER PHOTO MICROSCOPE.

Parts required as for Model 56.

This Model is identical with Model 56, and for the purpose of taking photographs is operated exactly as described for Model 59, a photographic plate being substituted for the Frosted Glass Screen after focussing.

Read the article on "Photomicrography" on p. 64, of the *Construmag*, May, 1933.

MODELS 61A and 61B.—HAND KALEIDOSCOPES.

Parts required:—

2	Ring Mounts	(3) or (3a)
1	Optical Tube	(4)
2	Split Rings	(10)
2	3in. Screwed Rods	(11)
8	Hexagonal Nuts	(15)
1	Lens	(17) or (18)
3	Strip Mirrors	(19)
2	Rubber Bands	(37)

Take the Strip Mirrors (19) and place them in the form of a triangle and secure with Rubber Bands (37) as shown at "A." Note that the Mirror surfaces should all face inwards. Insert the triangle of Mirrors in the Optical Tube (4) as at "B." Fix the Lens Stop (37a) in one of the Ring Mounts (3a) with a Split Ring (10) (this is the eye-piece). Mount the Optical Tube (4), complete with Mirrors, between the two Ring Mounts as described and illustrated in Fig. 5 A, B, C.

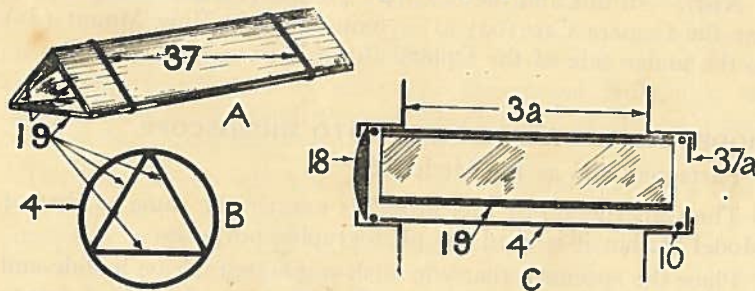

Mirrors for Models 61A and 61B.

Model 62A.

The Hand Kaleidoscope may be used to view all manner of small objects either black and white or coloured. Place the objects where they are well illuminated from above and look at them through the Kaleidoscope. Move either the objects or the Kaleidoscope or revolve the Optical Tube and observe the

effects obtained. Suitable objects for examination are—black threads on a white background, or white or coloured threads on a black background, match sticks, wire, wool, sweet wrappings, tinsel, coloured inks on blotting paper, etc.

MODELS 62A, 62B and 62C.—MAGNIFYING KALEIDOSCOPE.

Models 61A and 61B may be converted into Models 62A and 62B by fixing a Bi-Convex Lens (17) with a Split Ring (10) in the opposite end of the Model from the Stop. View through the end containing the Lens.

To build Model 62C fix a Plano-Convex Lens (18) with a Split Ring (10) in the opposite end to the Stop of Models 61A or 61B, (37a) and view through the Stop.

MODEL 63.—ILLUMINATED KALEIDOSCOPE. (Box Type with Lamp.)

Parts required:—

1	Optical Box	(1)
1	Lid for Optical Box	(2)
1	Screwed Ring Mount	(3)
1	Plain Ring Mount	(3a)
1	Lamp Holder	(5)
1	Split Ring	(10)
3	lin. Screwed Bolts	(12)
2	Terminal Nuts	(14)
4	Hexagonal Nuts	(15)
1	Bi-Convex Lens	(17)
1	Plano-Convex Lens	(18)
1	Bi-Convex Bulb	(25)
1	lin. Frosted Disc	(26)

Attach any of the Models 61 or 62 to the Optical Box (1) with Lid (2) in the same way as it is attached to the Instrument Stand (38) in Model 64. The distance of the Kaleidoscope from the Stand should be adjusted to give the best effect. An Electric Bulb (25) is fitted to the Optical Box (1) as in Fig. 7, p. 19. A Frosted Disc (26) may be mounted in a Ring Mount (3a) below the large central hole of the Optical Box (1) to prevent glare.

MODEL 64.—ILLUMINATED KALEIDOSCOPE. (Stand Type.)

Parts required as for Model 63, but the Instrument Stand (38) instead of the Optical Box (1).

Build as Model 63 but use the Instrument Stand (38) instead of the Optical Box (1).

MODEL 65.—ILLUMINATED KALEIDOSCOPE. (Stand Type B.)

Build as Model 64 but use a Reflector (42) as in Fig. 6, p. 19, instead of the Lampholder (5) and Electric Bulb (24).

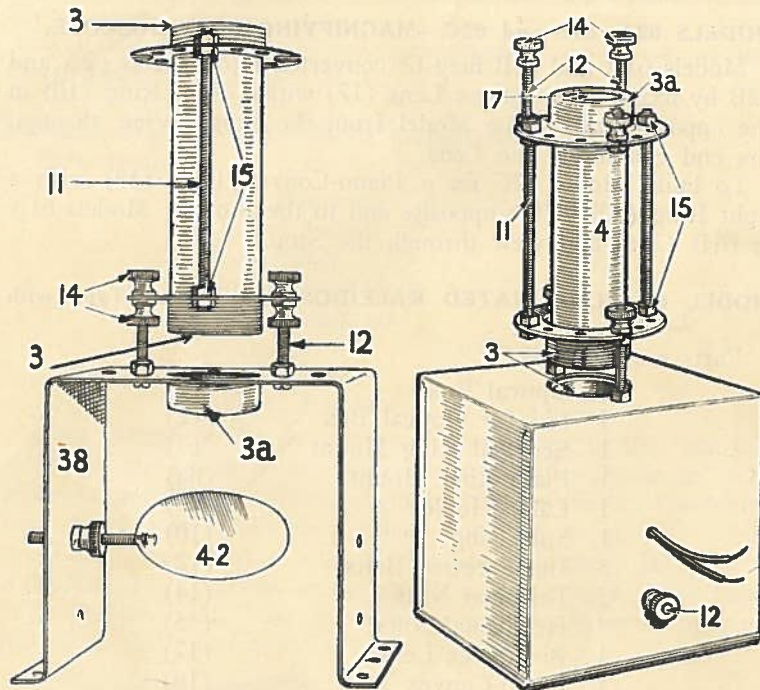

Model 65.

Model 66A.

MODELS 66A and 66B.—REFLECTION KALEIDOSCOPE. (Box Type.)

Parts required:—

As for Model 63 together with the following—

2	1in. Screwed Bolts	(12)
1	$\frac{1}{2}$ in. Screwed Bolt	(13)
3	Terminal Nuts	(14)
1	Square Mirror	(20)

Build Model 66A or 66B exactly as Model 63 but fit two 1in. Screwed Bolts (12) and one $\frac{1}{2}$ in. Screwed Bolt (13) to the top Ring Mount to form a Mirror Holder. (See diagram.) Place the Square Mirror (20) on the holder and adjust its position with the upper Terminal Nuts (14) of the Mirror Holder.

Place the object in its usual position under the Kaleidoscope and look into the Mirror with the eye close to it. You will then see a reflected image by looking into the horizontal reflection of the Optical Tube.

MODELS 67A and 67B.—REFLECTION KALEIDOSCOPE. (Projection Type.)

Build as Models 66A or 66B but fix a Bi-Convex Lens (17) in the upper Ring Mount (3) to act as an eye-piece, and a Plano-Convex Lens (18) in the lower Ring Mount (3) at the bottom of the Optical Tube (4) with its curved side downwards. The lenses are fixed by means of Split Rings (10).

Use Model 67A or 67B in a dark room. Hold a sheet of white paper or card from 15 inches to 18 inches from the Mirror and the Kaleidoscopic image will appear on it. Move the paper backwards or forwards until the most distinct image is obtained. By turning the Optical Tube (4) or by moving the slides or other subjects to and fro, you can create an ever-changing display of patterns and designs.

MODELS 68A and 68B.—REFLECTION KALEIDOSCOPE. (Projection Type.)

Substitute a Plano-Convex Lens (18) for the Bi-Convex Lens (17) in Model 67A or 67B.

Use these Models in the same way as Models 67A or 67B but hold the white paper or card at a distance of about 4 inches from the Mirror (20).

MODELS 69A and 69B.—HAND MICRO-KALEIDOSCOPE.

Construct exactly as Model 62A or 62B but fix a Plano-Convex Lens (18) in the Ring Mount (3) not already occupied by the Bi-Convex Lens (17). Use a Split Ring (10) to fix the Lens.

Hold the Model very close to the object to be viewed (about 1 inch from it) taking care to have the object in a good light. Hold transparent or semi-transparent objects up to the light. Try the effect of using either end of the Kaleidoscope as the eye-piece.

MODEL 70.—MICRO-KALEIDOSCOPE. (Stand Type.)

Mount Model 69 on an Instrument Stand (38) in the same way as Model 65. To illuminate the Object which is placed on the Instrument Stand (38) use either a Reflector (42) or an Electric Lamp (24), fixed to the stand in the usual way. For lamp illumination use a Ring Mount (3a) below the Instrument Stand (38) with a Frosted Disc (26) as in Model 63.

MODEL 71.—HIGH POWER MICRO-KALEIDOSCOPE.

Construct as Model 65 but screw the High Power Objective (41) and its Mount (41a) to the lower Ring Mount (3) of the Kaleidoscope before fixing it to the Instrument Stand (38), using 2in. Screwed Bolts (46) instead of 1in. Screwed Bolts (12). Reflector or Lamp may be used for illumination.

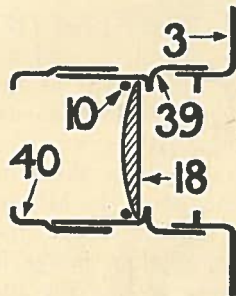

Lens arrangement for Model 72.

MODEL 72.—TELE-KALEIDOSCOPE.

Parts required:—

2 Screwed Ring Mounts	(3)
1 Optical Tube	(4)
2 Split Rings	(10)
2 3in. Screwed Rods	(11)
4 Terminal Nuts	(14)
4 Hexagonal Nuts	(15)
1 Bi-Convex Lens	(17)
1 Plano-Convex Lens	(18)
2 Strip Mirrors	(19)
2 Rubber Bands	(37)
1 Tubular Mount	(39)
1 Tubular Mount Cap	(40)

Construct as shown with a Plano-Convex Lens (18) in the Tubular Mount (39) and a Bi-Convex Lens (17) in the Ring Mount (3) at the other end of the Optical Tube (4). View through the Bi-Convex Lens end of the Kaleidoscope and a telescopic effect will be obtained.

MODEL 73.—REVERSED TELE-KALEIDOSCOPE.

Parts required:—As for Model 72 but in addition—

1 Distance Ring (8) 1 Plano-Convex Lens (18)

Model 73 is constructed in the same way as Model 72 but the Tubular Mount (39) is fitted with two Plano-Convex Lenses (18) separated by a Distance Ring (8) as shown in diagram.

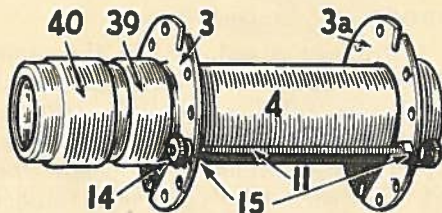
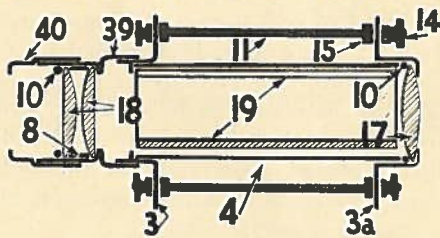

Model 73.

is fitted with two Plano-Convex Lenses (18) separated by a Distance Ring (8) as shown in diagram.

Look into the end of the Kaleidoscope containing the Bi-Convex Lens at bright objects at the end of a room, such as flowers, windows, furniture, etc. The Kaleidoscopic patterns are thrown to a distance as when looking through a reversed telescope.

MODEL 74.—PROJECTION KALEIDOSCOPE.

Parts required:—

1 Optical Box	(1)
2 Screwed Ring Mounts	(3)
1 Plain Ring Mount	(3a)
1 Optical Tube	(4)
1 Lampholder	(5)
2 Split Rings	(10)
2 3in. Screwed Rods	(11)
1 1in. Screwed Bolt	(12)
2 ½in. Screwed Bolts	(13)
5 Terminal Nuts	(14)
14 Hexagonal Nuts	(15)
1 Plano-Convex Lens	(18)
3 Strip Mirrors	(19)
1 Frosted Glass Screen	(22)
1 Focus Electric Bulb	(24)
1 1in. Frosted Disc	(26)
2 Elastic Bands	(37)
1 Lens Stop	(37a)
1 Instrument Stand	(38)
2 2in. Screwed Bolts	(46)

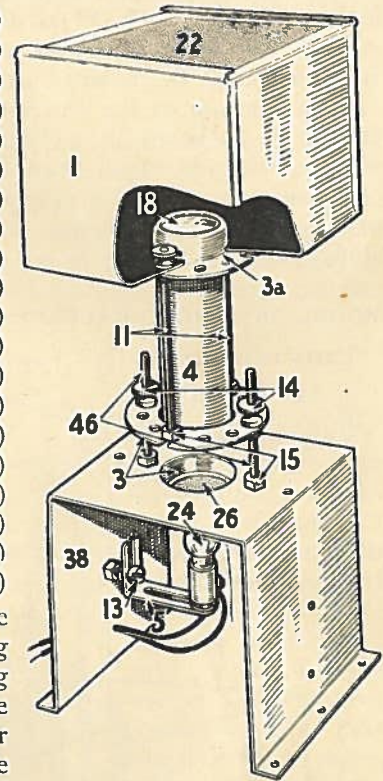

Model 74.

Build up a Hand Kaleidoscope (Model 61), but before securing the 3in. Rods to the upper Ring Mount (3) insert their free ends through the holes on either side of the large central hole of the Optical Box (1) and secure them inside the Box by Terminal Nuts (14). This assembly is then mounted on the Instrument Stand (38) with two 2in. Screwed Bolts at a distance from the Stand (38) as indicated in the picture. A Plano-Convex Lens (18) is inserted into the upper Ring Mount (3) from inside the Optical Box (1), the curved side of the Lens being upwards. Adjust the distance of the lower Ring Mount (3) from the Instrument Stand (38) so that a clear image is obtained on a Frosted Glass Plate (22) resting on the ledges at the top of the Optical Box (1).

The Instrument Stand (38) is provided with a Ring Mount (3) on its under side in which a Frosted Disc (26) is fixed by means of a Split Ring (10). Lamp illumination may be used as shown or Reflector (42), fitted as in Model 26, may be used instead of the Lamp and Lamp Holder.

Model 74 is particularly interesting and novel. It may be used in daylight or in a dark room for projecting kaleidoscopic images, patterns, etc., on the Frosted Glass Screen (22) which rests on the ledges at the top of the Optical Box (1). Objects for use should be mounted over the illuminated Frosted Disc (26) on the top of the Instrument Stand (38). Small objects should be mounted in a Glass Slide (23). Transparencies, coloured threads, small opaques illuminated from above, tiny cellophane or celluloid scraps sandwiched between glass slides, match sticks, cinema films, etc. make interesting objects for study.

MODEL 75.—PHOTO-KALEIDOSCOPE.

Parts required :—

As Model 74.

Build in exactly the same way as Model 74 but attach a Camera Cap (6) to the lower Ring Mount (3). A Construments Photo-Plate or Photo-Paper may be substituted for the Frosted Glass Screen (22) and a photograph of the Kaleidoscopic image may be taken.

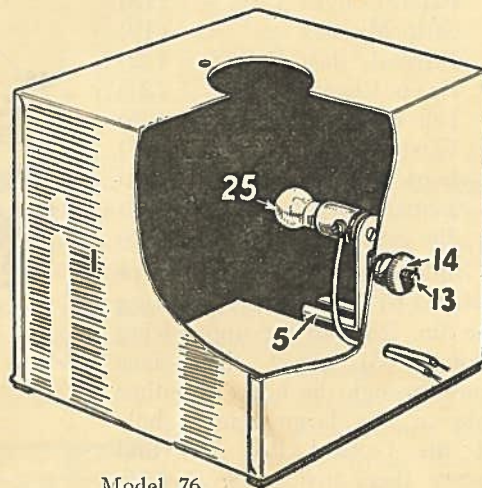

Model 76.

MODEL 76.—WATCH PROJECTOR. (Reflection Type.)

Parts required :—

1 Optical Box	(1)
1 Ring Mount	(3a)
1 Lamp Holder	(5)
1 Split Ring	(10)
4 1in. Screwed Bolts	(12)
2 ½in. Screwed Bolts	(13)
6 Terminal Nuts	(14)
6 Hexagonal Nuts	(15)
1 Bi-Convex Lens	(17)
1 Square Mirror	(20)
1 Bi-Convex Electric Bulb	(25)

Attach a Lampholder (5) and Bi-Convex Electric Bulb (25) to the Optical Box (1) as shown. In the picture the Lamp is not in a suitable position. See Models 87 and 88 for correct Lamp position.

MODEL 77.—WATCH PROJECTOR.

Parts required as for Model 47.

Build up exactly as Model 47, but use for projecting the image of the face of a watch on the Frosted Glass Screen (22), mounted in the back of the Optical Box (1). Owing to the thickness of the watch, the lens distance from it is not quite the same as in Model 47. Adjustment for sharp focus may be made by fixing the Optical Box (1) at a slightly different distance from the Instrument Stand (38).

MODEL 78.—EPIDIASCOPE. (Direct Projection.)

Parts required :—

1 Optical Box	(1)	4 Terminal Nuts	(14)
1 Lid for Optical Box	(2)	1 Bi-Convex Lens	(17)
1 Screwed Ring Mount	(3)	1 Bi-Convex Electric Bulb	(25)
1 Lamp Holder	(5)	1 Tubular Mount	(39)
1 Split Ring	(10)	1 Tubular Mount Cap	(40)
4 ½in. Screwed Bolts	(13)		

Construct according to the diagram. Attach a small picture to the centre of the Lid (2) of the Optical Box (1), using a little wax or with

Indiarubber Bands. Cigarette cards, postage stamps, crests, etc., are suitable subjects. The position of the Electric Lamp (25) should be carefully adjusted so that as much light as possible falls on the picture. Hold a sheet of cardboard at a suitable distance

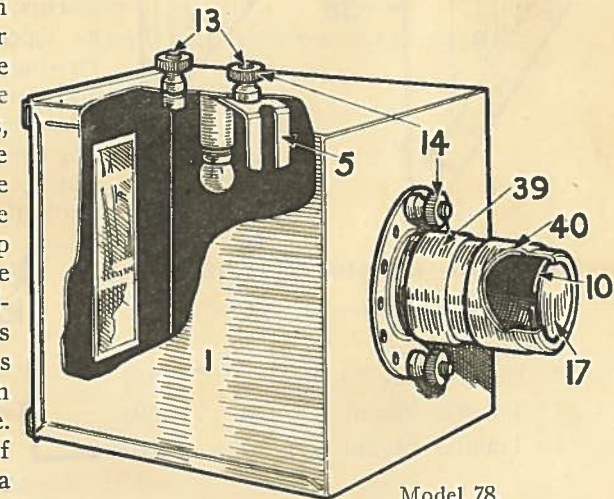

Model 78.

in front of the Epidiascope to catch the image and move the cardboard until the image is as sharp as possible.

A full description of Construments Epidiascopes is given in the March-April issue of the *Construmag*, 1933, p. 50.

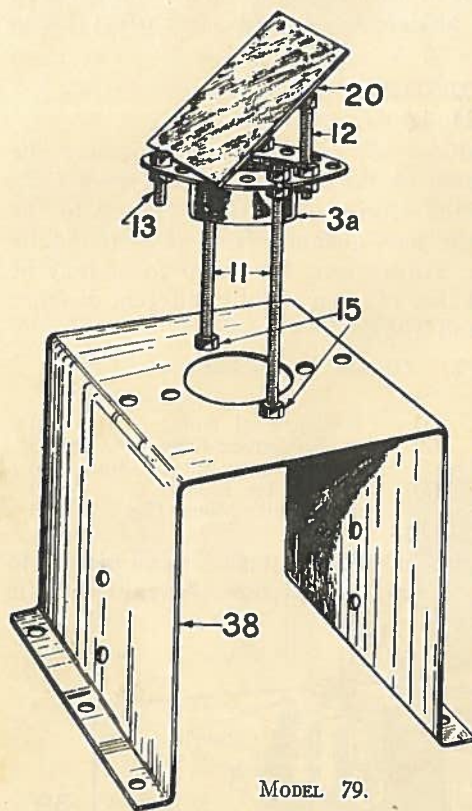
MODEL 79.—REFLECTOSCOPE.

MODEL 79.

Parts required:—

- | | | |
|----|--------------------------------|--------------|
| 1 | Ring Mount | (3) or (3a) |
| 1 | Split Ring | (10) |
| 2 | Screwed Rods | (11) |
| 2 | lin. Screwed Bolts | (12) |
| 1 | $\frac{1}{2}$ in. Screwed Bolt | (13) |
| 13 | Nuts | (15) |
| 1 | Lens | (17) or (18) |
| 1 | Mirror | (20) |
| 1 | Instrument Stand | (38) |

The Ring Mount (3) or (3a) should be fixed at a suitable height above the Instrument Stand (38) so that the object viewed is in focus.

This instrument is a "peep-show" for viewing small pictures, and can be used as a "Moviescope" for cinematograph films, which are passed beneath the lens.

MODEL 80.—RAMSDEN EYEPIECE.

Parts required:—

- | | | |
|---|---------------------|------|
| 2 | Split Rings | (10) |
| 2 | Plano-Convex Lenses | (18) |
| 1 | Tubular Mount | (39) |
| 1 | Tubular Mount Cap | (40) |

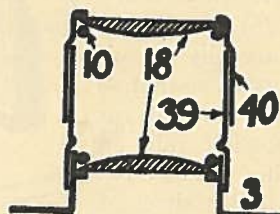

Model 80.

Mount one Lens (18) in the Tubular Mount (39) and the other in the Tubular Mount Cap (40), using Split Rings (10) as in Model Diagram.

The Ramsden Eyepiece is used in various optical instruments such as microscopes and telescopes.

MODEL 81.—REFRACTING ASTRONOMICAL TELESCOPE.

Parts required:—

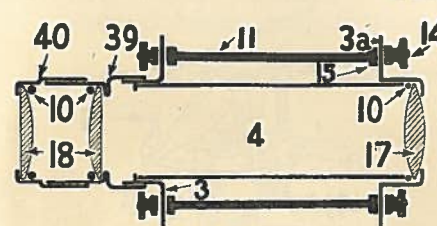

Model 81.

- | | | |
|---|---------------------|------|
| 1 | Screwed Ring Mount | (3) |
| 1 | Plain Ring Mount | (3a) |
| 1 | Optical Tube | (4) |
| 3 | Split Rings | (10) |
| 2 | 3in. Screwed Rods | (11) |
| 4 | Terminal Nuts | (14) |
| 4 | Hexagonal Nuts | (15) |
| 1 | Bi-Convex Lens | (17) |
| 2 | Plano-Convex Lenses | (18) |
| 1 | Tubular Mount | (39) |
| 1 | Tubular Mount Cap | (40) |

Mount the Optical Tube (4) between two Ring Mounts (3a) as in Fig. 5, p. 18. Fix a Bi-Convex Lens (17) in one Ring Mount (3a) by means of a Split Ring (10). Screw a Ramsden Eyepiece (Model 80) on the other Ring Mount (3). View through the Ramsden Eyepiece which may be used to focus the image which is inverted. Model 81 is a miniature Refracting Astronomical Telescope.

Model 81 may be used to view the moon, distant buildings, landscapes, etc. It is impossible to obtain a high magnification with so short an instrument.

MODEL 82.—MEDIUM POWER PROJECTION MICROSCOPE.

Parts required:—

- | | | |
|----|--------------------------------|------|
| 1 | Optical Box | (1) |
| 1 | Lid for Optical Box | (2) |
| 2 | Screwed Ring Mounts | (3) |
| 1 | Plain Ring Mount | (3a) |
| 1 | Lamp Holder | (5) |
| 1 | Distance Ring | (8) |
| 1 | Split Ring | (10) |
| 2 | 3in. Screwed Rods | (11) |
| 3 | lin. Screwed Bolts | (12) |
| 1 | $\frac{1}{2}$ in. Screwed Bolt | (13) |
| 3 | Terminal Nuts | (14) |
| 17 | Hexagonal Nuts | (15) |
| 2 | Plano-Convex Lenses | (18) |
| 1 | Square Mirror | (20) |
| 1 | Bi-Convex Electric Bulb | (25) |
| 1 | Tubular Mount | (39) |

Model 82 is used for horizontal projection. It is used for throwing an image of pond life on a screen. The pond life is put into an aquarium constructed as in Fig. 8C, p. 20.

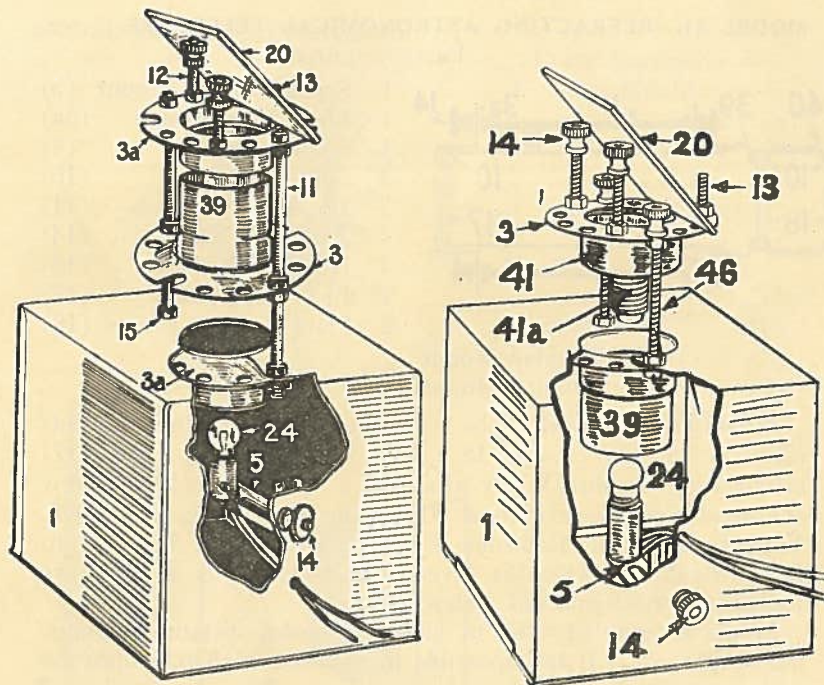

Model 82.

Model 83.

MODEL 83.—HIGH POWER PROJECTION MICROSCOPE.

Parts required:—

1 Optical Box	(1)
1 Lid for Optical Box	(2)
2 Screwed Ring Mounts	(3)
1 Lamp Holder	(5)
1 Distance Ring	(8)
1 Split Ring	(10)
3 1in. Screwed Bolts	(12)
1 ½in. Screwed Bolt	(13)
5 Terminal Nuts	(14)
9 Hexagonal Nuts	(15)
2 Plano-Convex Lenses	(18)
1 Square Mirror	(20)
1 Bi-Convex Electric Bulb	(25)
1 Tubular Mount	(39)
1 High Power Objective	(41)
1 Mount for High Power Objective	(41a)
2 2in. Screwed Bolts	(46)

Model 83 is used for horizontal projection. It is used in the same way as Model 82 where the objects are very small or where a higher magnification is required.

MODEL 84.—CHEMICAL MICROSCOPE.

Parts required:—

2 Screwed Ring Mounts	(3)
1 Optical Tube	(4)
1 Lamp Holder	(5)
1 Distance Ring	(8)
2 Split Rings	(10)
2 3in. Screwed Rods	(11)
1 ½in. Screwed Bolt	(13)
4 Terminal Nuts	(14)
9 Hexagonal Nuts	(15)
4 Plano-Convex Lenses	(18)
1 Focus Electric Bulb	(24)
1 Instrument Stand	(38)
2 Tubular Mounts	(39)
1 Tubular Mount Cap	(40)
1 Stop for Lens	(44a)

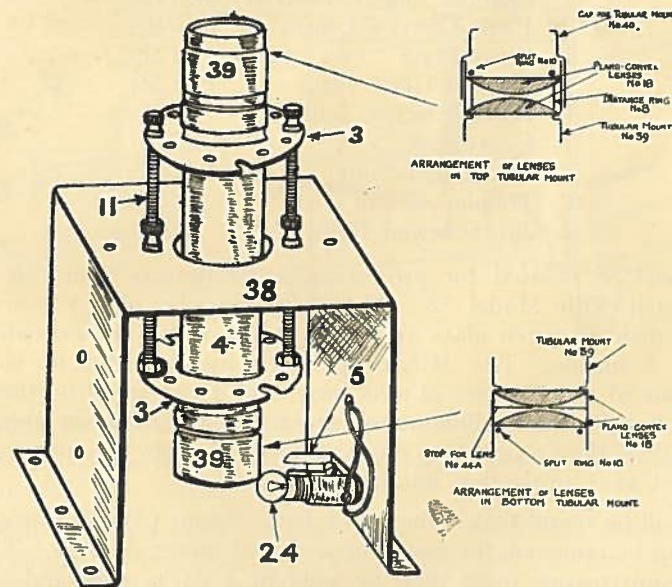

Model 84.

Model 84 is used for observing the growth of crystals, formation of bubbles or precipitates. Vapour or spray is not

so likely to dim the lenses of the objective which are somewhat removed from the vessel in which the change is proceeding. This form of microscope gives moderate space in which to work. Focussing is carried out partly by means of the terminal nuts on the Instrument Stand (38) and finally by turning the Objective.

MODEL 85.—MEDIUM POWER PROJECTION MICROSCOPE OR PHOTO-MICROSCOPE. (For Opaque Objects.)

Parts required:—

1	Optical Box	(1)
1	Lid for Optical Box	(2)
2	Screwed Ring Mounts	(3)
1	Lamp Holder	(5)
1	Camera Cap	(6)
2	Battery Clips	(7)
1	Split Ring	(10)
2	3in. Screwed Rods	(11)
3	$\frac{1}{2}$ in. Screwed Bolts	(13)
7	Terminal Nuts	(14)
10	Hexagonal Nuts	(15)
1	Spanner and Screwdriver	(16)
2	Plano-Convex Lenses	(18)
1	Glass Plate	(21)
1	Frosted Glass Plate	(22)
1	Focus Electric Bulb	(24)
1	Lens Stop	(37a)
1	Instrument Stand	(38)
1	Tubular Mount	(39)
2	2in. Screwed Bolts	(46)

Model 85 is used for projecting larger objects than can be projected with Model 55. Model 85 may be placed over a small dish or watch glass or any object of width not exceeding about 3 inches. The Microscope may also be used to view portions of much larger objects providing it can stand on them. The object must be illuminated from the side or from above. Of course, the Camera Cap must be removed when the apparatus is used as a projection microscope.

It will be found that if the upper Ring Mount (3) and Camera Cap (6) be removed, the resulting projected image is larger. The Photo-microscope must then be used in a dark room and the Focus Lamp (24) unscrewed until everything is ready for an exposure. The Lamp is now screwed up again, when the necessary exposure has been given. Alternatively, one battery

wire may be disconnected from the battery until everything is ready for an exposure, and then the bare wire pressed into contact with the battery terminal for a suitable number of seconds.

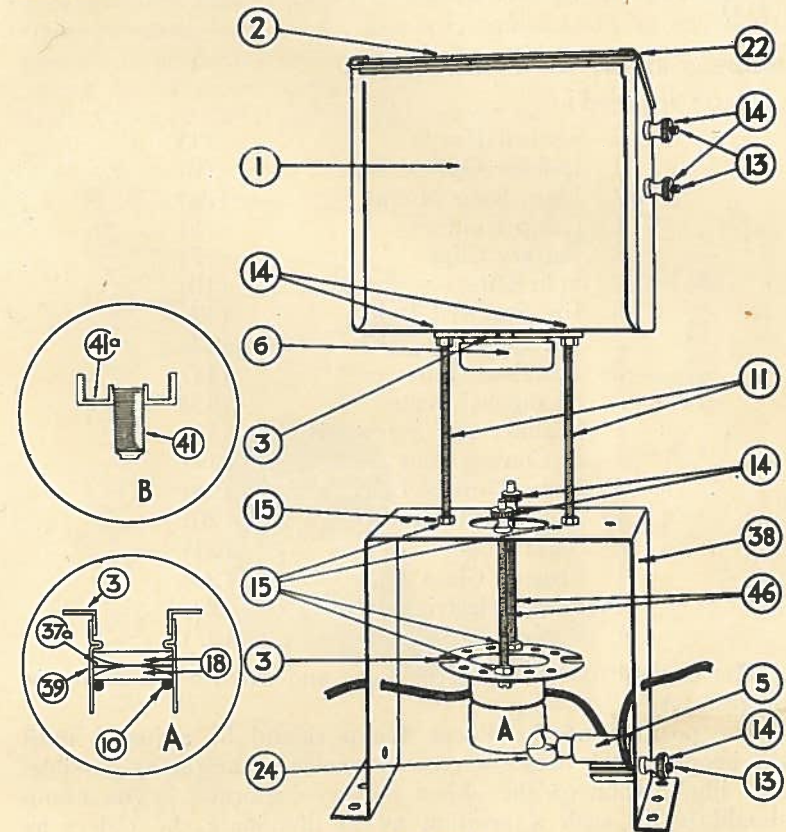

Models 85 & 86.

MODEL 86.—HIGH POWER PROJECTION MICROSCOPE.

Model 86 is used for projecting larger objects than can be projected with Model 56.

It is exactly similar in construction to Model 85, except that the High Power Objective (B) is substituted for the Medium Power Objective (A). (See diagram.) This Model may also be used as a Photo-microscope. The previous remarks relating to the removal of the upper Ring Mount and Camera Cap apply to this Model also.

The parts required for constructing Model 86 are the same as for Model 85, omitting the components of A (Tubular Mount, 2 Plano-Convex Lenses, Split Ring, Lens Stop) and substituting the High Power Objective (B) for A. B. consists of (41) and (41a).

MODELS 87 and 88.—EPIDIASCOPES.

Parts required :—

1 Optical Box	(1)
1 Lid for Optical Box	(2)
1 Plain Ring Mount	(3a)
1 Lamp Holder	(5)
2 Battery Clips	(7)
1 Split Ring	(10)
4 1in. Screwed Bolts	(12)
2 ½in. Screwed Bolts	(13)
5 Terminal Nuts	(14)
7 Hexagonal Nuts	(15)
1 Spanner and Screwdriver	(16)
1 Bi-Convex Lens	(17)
1 Plano-Convex Lens	(18)
1 Square Mirror	(20)
1 Glass Plate	(21)
1 Frosted Glass Plate	(22)
1 Focus Electric Bulb	(24)
1 Rubber Band	(37)

The method of mounting the Lens and Mirror are shown in diagram A.

The position of the Focus Lamp should be adjusted until the image of the object on the Screen is as bright as possible. The illumination of the object is very important. The Lamp should be in such a position as to illuminate the object as brightly as possible. At the same time the Lamp must not give an image on the Screen. To prevent stray light from the Lamp falling on the Screen, a little tin foil (chocolate wrappings) may be fixed with an Indiarubber Band so as to cover the upper side of the Lamp. The tin foil prevents the light from passing upwards and also reflects extra light to the object.

The Ring Mount carrying the Lens may be fixed at various distances from the Optical Box according to the size of the image required and its distance from the Epidiastroscope. Exact focussing may be carried out by adjusting the Ring Mount. Again, the Plano-Convex Lens may be substituted for the Bi-Convex Lens if smaller but brighter pictures are required. Small

images are suitable for photography and for preparing photographic enlargements.

Only small objects may be used in conjunction with Model 87, such as coins, face or works of a watch, crests, postage stamps, cigarette cards, insects in a live box, pond life in an aquarium, crystals in a watch glass, or on a glass slide, flowers, etc. The object, if white or coloured, should be placed on a sheet of black paper or card, and if dark, on a sheet of white paper or card.

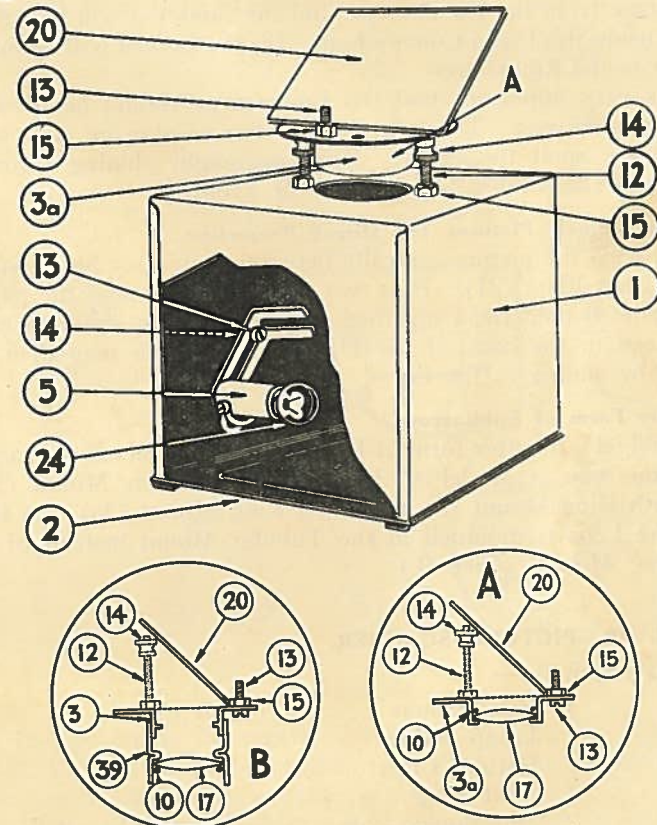

Models 87 & 88.

The Mirror of the Epidiastroscope is for the purpose of preventing the inversion of printed matter on the Screen. If the inversion of the image is unimportant, the Mirror may be removed and the image projected on the ceiling, or the Epidiastroscope may be used without the Mirror, but turned on its side so as to project the picture on to a Wall or Screen.

To Find the Correct Screen Distance.

This is easily done by using the Epi-diascope without the Mirror and turned on its side. A candle flame or flash-light may be held at the back of the Optical Box where the object is usually placed. It is easy to obtain a sharp image of the flame or filament of the flash-lamp on a Screen when the Screen is at the correct distance from the Epi-diascope. The Screen distance so found will be nearly the same as for the Models. Remember that the nearer the Lens is fixed to the object the further is the image from the Epi-diascope, and the fainter it will be. Also when using the Plano-Convex Lens (18) the Screen will be much nearer to the Epi-diascope.

It is very important that the Epi-diascope should be used in absolute darkness. The light from a fire or glowing coals will completely spoil the effect. Even moonlight shining through curtains or a window-blind should be avoided.

Mounting Small Pictures for Direct Projection.

Sandwich the picture centrally between a piece of black paper and a glass Plate (21). Pass two elastic bands round the paper and plate to hold them together. The picture so mounted may be placed in the back of the Optical Box which may then be closed by sliding in the lid.

A Better Form of Epi-diascope.

Model 88 is a better form of Epi-diascope constructed in exactly the same way as Model 87, but with the Tubular Mount (39) and with Ring Mount (3) instead of Ring Mount (3a). In this case the Lens is mounted in the Tubular Mount instead of in the Ring Mount. (See B.)

MODEL 89.—PICTURE SCANNER.

Parts required:—

1 Ring Mount	(3) or (3a)
1 Lamp Holder	(5)
2 Battery Clips	(7)
1 Split Ring	(10)
2 1in. Bolts	(12)
1 ½in. Bolt	(13)
2 Terminal Nuts	(14)
7 Hexagonal Nuts	(15)
1 Spanner and Screwdriver	(16)
2 Glass Slides	(23)
1 Focus Bulb	(24)
1 Frosted Disc	(26)

2 Rubber Bands	(37)
1 Instrument Stand	(38)
or	
1 Optical Box	(1)
1 Scanning Disc.	

The Scanning Disc is made as follows:—

Cut out a cardboard disc of radius $1\frac{1}{2}$ ins. Draw radii on the card every 15 deg. Number these radii 1, 2, 3, etc to 24. Make points on these radii as follows. On radius 1, make a point $\frac{1}{2}$ in.

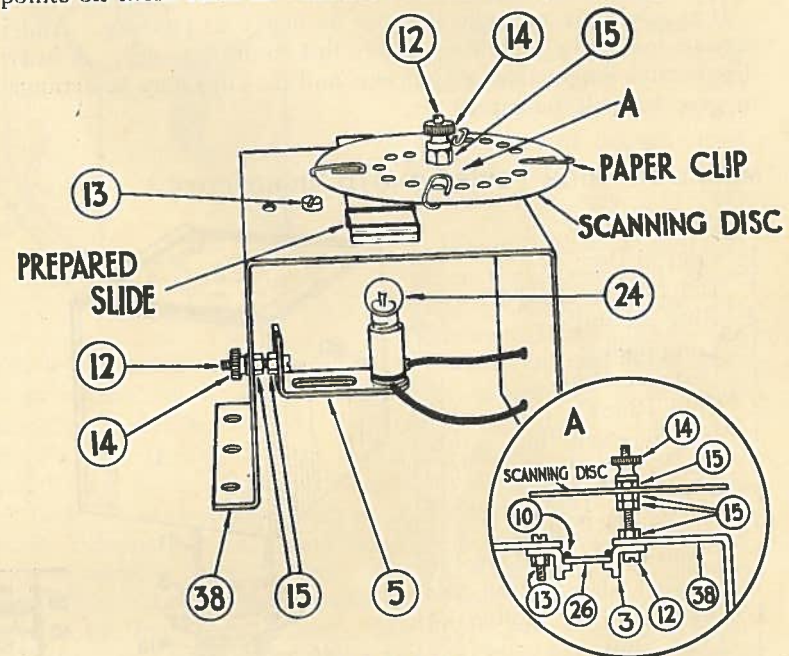

Model 89.

or $\frac{16}{32}$ in. from the centre of the disc. On radius 2, mark a point $\frac{17}{32}$ in. from the centre of the disc. The distances from the centre of the disc of the points on radii 3, 4, 5, etc., are $\frac{18}{32}$ in., $\frac{19}{32}$ in., $\frac{20}{32}$ in., etc., each distance increasing by $\frac{1}{32}$ in. for the next radius. The distance along the radius 24 is $\frac{39}{32}$ in. of an inch. At each of the points marked along a radius, pierce a hole about $\frac{1}{16}$ in. in diameter. The leg of a pair of compasses or dividers may be used for this purpose. Finally, pierce a hole in the centre of the disc $\frac{3}{16}$ in. in diameter.

Model 89 is an arrangement for scanning a small picture such as a small lantern slide or portion of a cinematograph film.

For daylight use the Reflector (42); Battery Clips and Focus Bulb are not required, but Reflector (42) may be attached to the Instrument Stand to reflect the daylight on to the picture.

Mount a small picture from a cinematograph film between two Glass Slides held together with Rubber Bands. Place this prepared slide on the Instrument Stand of Model 89 and illuminate the picture. Rotate the Scanning Disc at various speeds and look through the Scanning Disc at the picture. The faster the disc is rotated the clearer the picture becomes.

It is advisable to make the disc as heavy as possible. And it may be loaded by attaching paper clips round its edge. A heavy disc rotates longer than a light one, and the clips may be arranged to give suitable balance.

MODEL 90.—HIGH POWER PHOTO-MICROSCOPE.

Parts required :—

- | | | |
|----|---------------------------------|-------|
| 1 | Optical Box | (1) |
| 1 | Lid for Optical Box | (2) |
| 2 | Ring Mounts | (3) |
| 1 | Lampholder | (5) |
| 1 | Distance Ring | (8) |
| 2 | Split Rings | (10) |
| 1 | 1in. Screwed Bolt | (12) |
| 2 | $\frac{1}{2}$ in. Screwed Bolts | (13) |
| 7 | Terminal Nuts | (14) |
| 12 | Hexagonal Nuts | (15) |
| 3 | Plano-Convex Lenses | (18) |
| 1 | Frosted Glass Screen | (22) |
| 1 | Focus Electric Bulb | (24) |
| 1 | Lens Stop | (37a) |
| 1 | Instrument Stand | (38) |
| 1 | Tubular Mount | (39) |
| 1 | Cap for Tubular Mount | (40) |
| 1 | High Power Objective | (41) |
| 1 | Mount for High Power Objective | (41a) |
| 2 | Spring Clips | (43) |
| 4 | 2in. Screwed Bolts | (46) |

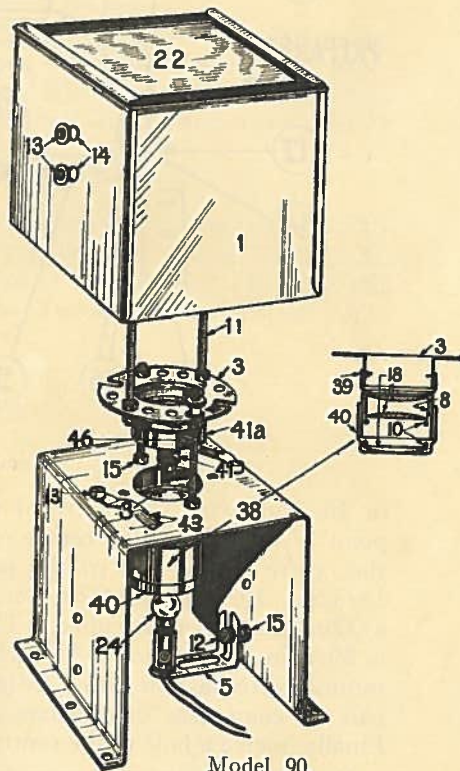

Model 90.

Construct according to diagram. Read also Model 91.

MODEL 91.—MEDIUM POWER CHEMICAL MICROSCOPE.

Parts required :—

- | | | |
|---|--------------------------------|------|
| 2 | Ring Mounts | (3) |
| 1 | Lamp Holder | (5) |
| 2 | Split Rings | (10) |
| 2 | 3in. Screwed Rods | (11) |
| 1 | $\frac{1}{2}$ in. Screwed Bolt | (13) |
| 5 | Terminal Nuts | (14) |
| 7 | Hexagonal Nuts | (15) |
| 2 | Plano-Convex Lenses | (18) |
| 1 | Focus Bulb | (24) |
| 1 | Frosted Disc | (26) |
| 1 | Instrument Stand | (38) |
| 1 | Tubular Mount | (39) |
| 1 | Stop for Lens | (44) |

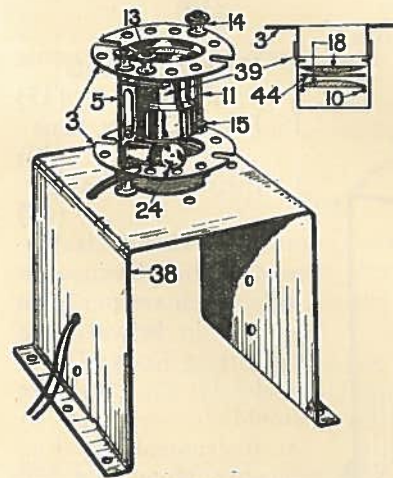

Model 91.

Mount a Ring Mount (3) on to the Instrument Stand (38) by means of two 3in. Screwed Rods (11), and have it separated from the Stand by two Terminal Nuts (14) as in figure, with its screwed part projecting downwards through the centre hole of the Instrument Stand. Place the 1in. Frosted Disc (26) into the Ring Mount, and fix with a Split Ring. Now insert two Plano-Convex Lenses with a "Stop for Lens" (44) between them as in small diagram on the right into a Tubular Mount, fixing them by a Split Ring, and screw it on to another Ring Mount. Fix the Ring Mount to the top of the 3in. Screwed Rods, with the Tubular Mount projecting towards the Instrument Stand. Mount the Focus Lamp (24) in its Holder and fix the Holder to the top Ring Mount by means of a $\frac{1}{2}$ in. Screwed Bolt (13) as in figure so that the Bulb just rests between the top of the bottom Ring Mount and the bottom of the Tubular Mount.

Crystals, etc., may be viewed on slides through the top of the top Ring Mount, and slides must be placed on top of the bottom Ring Mount (between A and B in figure).

The Model may be focussed by screwing the Tubular Mount up and down.

MODEL 92.—LOW POWER MAGNIFIER. (Stand Type.)

Parts required:—

- | | |
|---------------------|------|
| 1 Plain Ring Mount | (3a) |
| 1 Split Ring | (10) |
| 2 3in. Screwed Rods | (11) |
| 8 Hexagonal Nuts | (15) |
| 1 Plano-Convex Lens | (18) |
| 1 Instrument Stand | (38) |

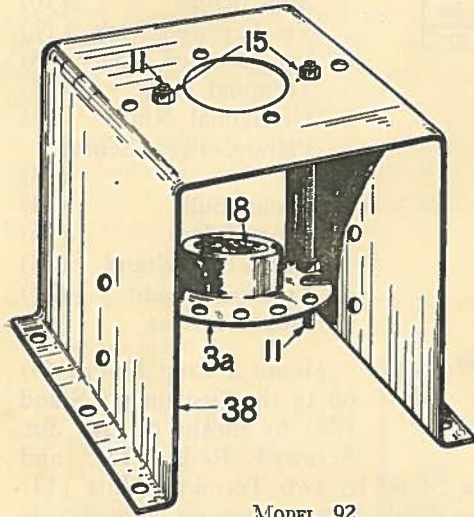

MODEL 92.

This Model is intended for viewing objects which are too large to pass in between the supporting Rods (11) in Model 11, the magnifier should be mounted in the Instrument Stand as shown. Note that the Lens is uppermost.

Adjustment for Focus is made on the screwed Rods.

MODEL 93.—REFLECTOR.

Parts required:—

- | | |
|----------------------|-------------|
| 1 Ring Mount | (3) or (3a) |
| 2 1in. Screwed Bolts | (12) |
| 1 ½in. Screwed Bolt | (13) |
| 5 Hexagonal Nuts | (15) |
| 1 Square Mirror | (20) |

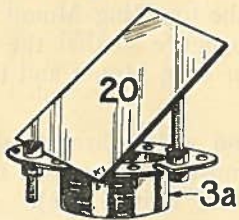

MODEL 93.

Adjustment of the angle of the Mirror (20) is obtained by raising or lowering the two Nuts (14 or 15) on which the Mirror (20) rests.

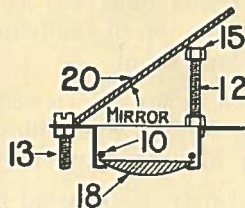

MODEL 94.

This model is useful as a reflector for Model 11.

Model 93A is as Model 93, but with the face of Mirror (20) reversed.

MODEL 94.—REFLECTOR (with lens).

Parts required:—

As for Model 4, and in addition:—

- | | |
|--------------|--------------|
| 1 Lens | (17) or (18) |
| 1 Split Ring | (10) |

For Model 94 a Plano-Convex Lens (18) can be mounted as shown or with the convex (curved) side uppermost. Note that the Mirror (20) should make an angle of 45 deg. with the Ring Mount.

For Model 94A a Bi-convex Lens (17) is used instead of the Plano-Convex Lens (18) of Model 94.

MODEL 95.—CAMERA LUCIDA.

Parts required:—

- | | |
|----------------------|--------------|
| 2 Ring Mounts | (3) or (3a) |
| 1 Split Ring | (10) |
| 2 Screwed Rods | (11) |
| 2 1in. Screwed Bolts | (12) |
| 3 ½in. Screwed Bolts | (13) |
| 15 Nuts | (14) or (15) |
| 1 Lens | (17) or (18) |
| 1 Square Mirror | (20) |
| 1 Instrument Stand | (38) |

Stand the Model on a sheet of white paper, with the Mirror facing towards the light and the inside of the Instrument Stand shielded from the light. Now hold a lighted candle in front of the mirror, varying the distance until a clear image is reflected on the white paper. A clear image may also be obtained by varying the height of the Ring Mount carrying the Lens in the Instrument Stand. Well illuminated objects, placed at a suitable distance from the mirror, will be reflected on the paper and can be traced or photographed.

For some distances of object the Lens (17) or (18) may be mounted in the upper Ring Mount, and in this case the lower Ring Mount need not be used.

For viewing transparent objects, the reflector (Model 93)

should be placed below the Instrument Stand (38) to reflect light on the object. Alternately the Reflector (42) may be used.

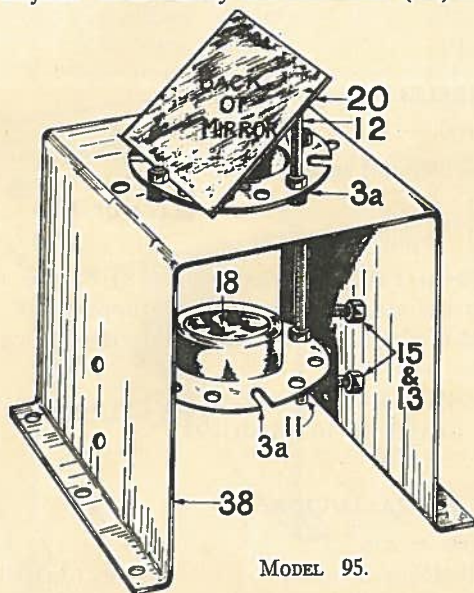

MODEL 95.

MODELS 96, 96A and 96B.—PINHOLE CAMERA.

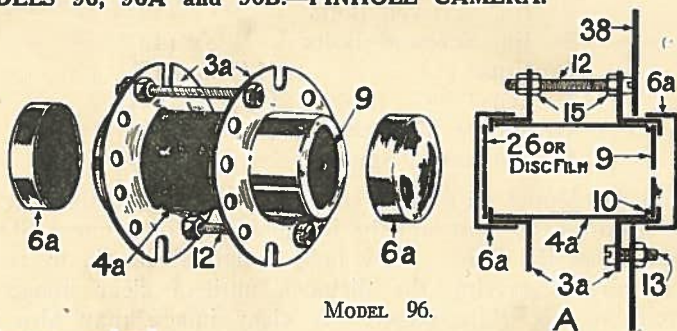

MODEL 96.

Parts required:—

2 Ring Mounts	(3) or (3a)
1 Optical Tube	(4a)
2 Camera Caps	(6) or (6a)
1 Pinhole Disc	(9)
1 Split Ring	(10)
2 1in. Screwed Bolts	(12)
6 Nuts	(14) or (15)
1 Frosted Disc	(26)

In assembling the Camera (shown diagrammatically at A) care should be taken that the Optical Tube is firmly held between the Ring Mounts, which must be parallel (see Fig. 5, A, B, and C). When taking photographs, it is necessary to support the Camera so that no movement takes place during the exposure. This may be done by resting the model on the Instrument Stand (38), as shown in Model 96A. Note that the two slots in the Ring Mount (3 or 3a) rest in the large hole of the Stand. The Camera may also be mounted on the Stand as shown in Model 96B. To take a trial photograph, remove the Camera Caps and point the pinhole to a good source of light. Hold the frosted disc over the free end and adjust the distance between the pinhole and the object until the image on the Frosted Disc is of suitable size.

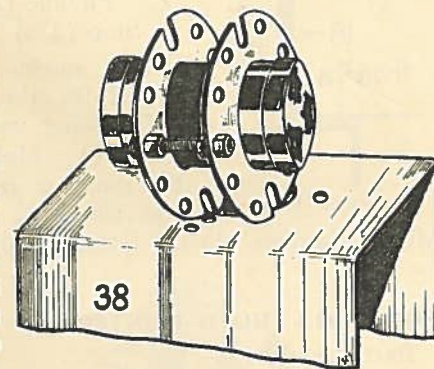

MODEL 96A.

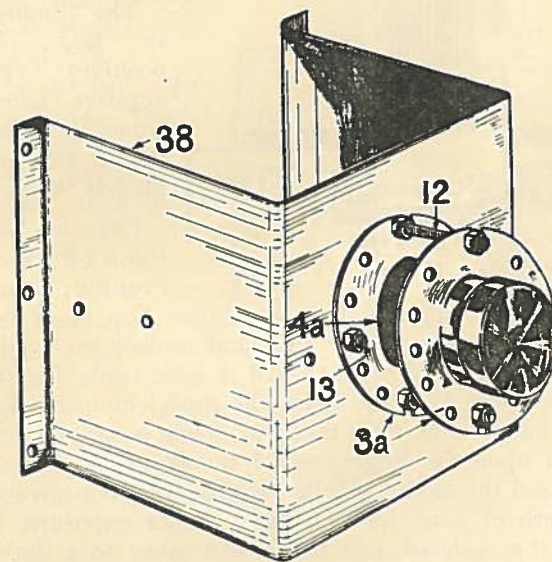

MODEL 96B.

MODEL 97.—LENS POCKET CAMERA.

Parts required:—

As for Model 96; in addition:—

- 1 Plano-Convex Lens (18) instead of Pinhole Disc (9);
- 1 Stop (37a).

This model is constructed exactly as Model 96, the Lens (18) and the Stop (37a) being used in place of the Pinhole Disc (9). Mountings for this model are the same as for Model 96. See Models 96A and 96B. Read the article on "The

Midget Camera," in the *Construmag*, September, 1933.

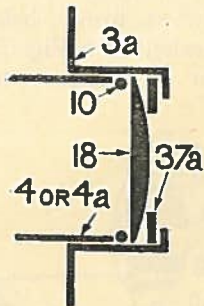

MODEL 97.

MODEL 98.—PHOTO PRINTER.

Parts required:—

- 2 Ring Mounts (3) or (3a)
- 2 Camera Caps (6) or (6a)
- 2 ½ in. Screwed Bolts (13)
- 2 Nuts (14) or (15)
- 1 Instrument Stand (38)

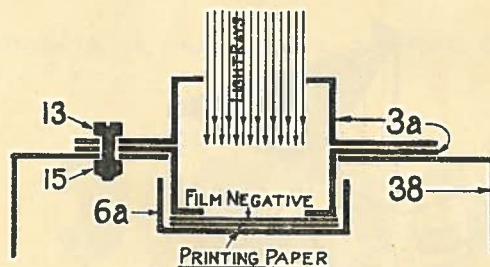

MODEL 98.

the sensitive side uppermost, in the lower Cap (6 or 6a). and place the Disc Negative over this, and replace the loaded Cap on the Ring Mount (3 or 3a). All is now ready for printing. Remove the upper Cap and place the model immediately below an electric lamp. The time taken to obtain a satisfactory print will depend upon the brightness of the lamp and the distance between it and the model, a little practice will soon give you the correct length of time for exposure. After exposure, the top Cap should be replaced, and the Model taken to a dark room, where the print may safely be removed and finished by developing and fixing in the ordinary way.

The Photo Printer is for obtaining positives from a negative taken with either the Pinhole or Pocket Lens Camera, Models 96 and 97.

Put a Disc of Photographic Printing Paper with

MODEL 99.—PHOTO COPIER.

Parts required:—

- 2 Ring Mounts (3) or (3a)
- 1 Optical Tube (4)
- 2 Camera Caps (6) or (6a)
- 1 Split Ring (10)
- 2 3 in. Screwed Rods (11)
- 2 1 in. Screwed Bolts (12)
- 14 Nuts (14) or (15)
- 1 Plano-Convex Lens (18)
- 1 Frosted Disc (26)
- 1 Instrument Stand (38)
- Sheet of Black Paper

Assemble the Optical Tube (4) as shown in Fig. 5 A, B, C.

The Lower Ring Mount (3 or 3a) is fitted with the Plano-Convex Lens (18). Mount the completed unit on the Instrument Stand (38) with Screwed Bolts (12) and Nuts (14 or 15).

This Model will copy small pictures, coins, stamps, diagrams, etc. Place the Model on black paper or a dark baseboard, with the object to be copied, immediately below the Lens, and resting on the black paper. Cover the upper Ring Mount (3 or 3a) with the Frosted Disc (26) and place the Model in a position where as much light as possible falls on the object. An image of the object will then be seen on the Frosted Disc. The Nuts (15) on Screwed Bolts (12) should be adjusted until a sharp image is obtained. Now place a Camera Cap (6 or

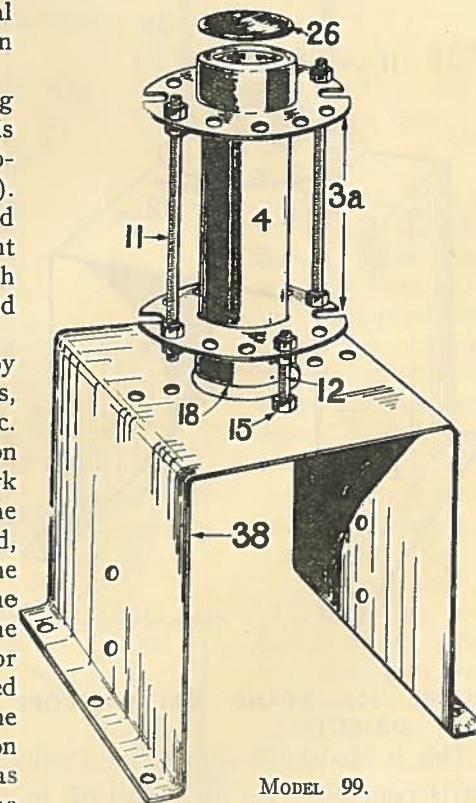

MODEL 99.

6a) on the lower Ring Mount and remove the Frosted Disc (26). Take the Model into a dark room, and place a Disc Film or Disc of Photographic Printing Paper over the upper Ring Mount and cover with a Camera Cap. Replace the Model over the object and expose for a suitable length of time. After exposure, develop and fix as usual.

Model 99 may be used to project small magic lantern slides, cinematograph pictures (cut out and sandwiched between two Glass Slides (23) encircled by Rubber Bands (37), prepared slides of crystals, insect parts, etc. The Photo Copier (without Camera Cap) is placed on white paper immediately below an electric lamp. The Slide is placed on the upper Ring Mount with the object over the hole in the Mount. An image of the object will be projected on to the white paper and may be sketched or photographed.

MODEL 100.— PROJECTOR.

Model 99 may be slightly modified as shown in Model 100, in which the Optical Tube (4) is omitted and the lower Ring Mount is reversed. This Model is not quite so suitable for photography.

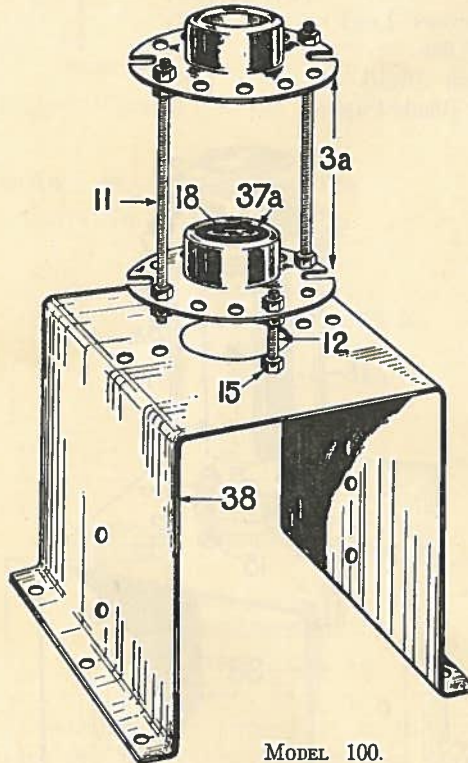

MODEL 100.

MODEL 101.—STAND KALEIDOSCOPE FOR TRANSPARENT OBJECTS.

This is Model 102 without the Cardboard Disc and Mount.

Parts required:—As for Model 62, in addition—

2	1in. Screwed Bolts	(12)
6	Hexagonal Nuts	(15)
1	Instrument Stand	(38)

Mount the Hand Kaleidoscope (Model 62) on the Instrument Stand (38) as shown.

Stand the instrument on a well illuminated white card and place the object to be viewed over the hole in the top of the Stand. Slides containing coloured cellophane clippings, pieces of cinematograph film, etc., can be mounted between Glass Slides (23), as shown in Fig. 6; and placed on the Instrument Stand.

MODEL 102.—STAND KALEIDOSCOPE FOR OPAQUE OBJECTS.

Parts required:—

As for Model 101—in addition:—

1	1in. Screwed Bolt	(12)
4	Hexagonal Nuts	(15)
1	White Cardboard Disc	3in. diam.

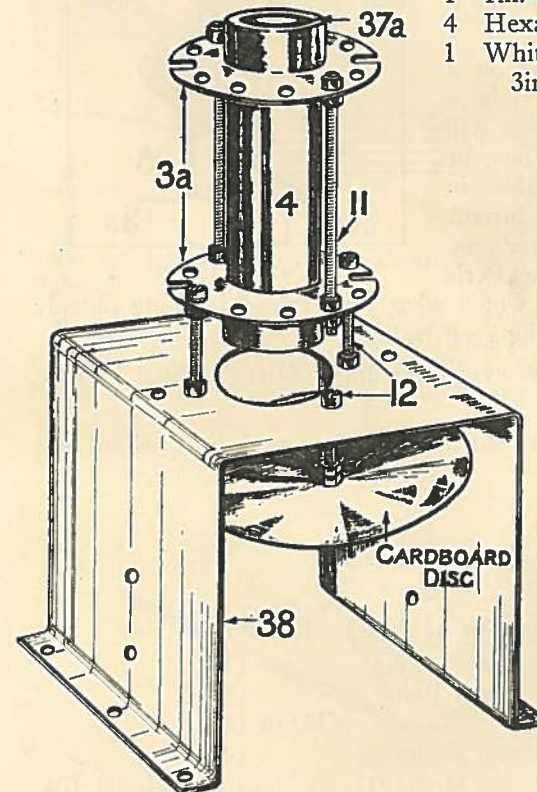

MODEL 102.

Mount the Cardboard Disc as shown. See that the two Nuts (15) on the top of the Disc are locked together to prevent them screwing up when turning the Disc.

Adjustment for focus can be made on the two Screwed Bolts (12), securing the Kaleidoscope to the Stand, and also on that on which the Disc is mounted. Place the objects to be viewed on the Disc and revolve the Disc.

MODEL 103.—PERISCOPE

Parts required :—

2	Ring Mounts	(3) or (3a)
4	1in. Screwed Bolts	(12)
2	$\frac{1}{2}$ in. Screwed Bolts	(13)
10	Nuts	(14) or (15)
2	Square Mirrors	(20)
1	Instrument Stand	(38)

This Model is composed of the Mirror Stands (Models 93 and 93A) and Instrument Stand (38). One Mirror Stand (Model 93A) rests in the large hole of the Instrument Stand, and the other (Model 93) is placed below it as shown.

Stand the Periscope on a table; objects on the table in front of the lower Mirror will be seen in the upper one, or objects above the table in front of the upper Mirror will be seen in the lower one. You can arrange the Periscope so that you can watch what your friend is doing outside a window without being seen by him.

Try the effect of revolving the upper Mirror whilst looking into it.

Use the Periscope to read the cards in a pack held behind and above the head.

MODELS 104 and 105.—CRAZY MIRRORS.

Parts required :—

As for Model 93 (but two of these). In addition :—

2	1in. Screwed Bolts	(12)
2	$\frac{1}{2}$ in. Screwed Bolts	(13)
6	Nuts	(14) or (15)
1	Instrument Stand	(38)

Arrange two Reflectors (Model 93) as shown in Model 104. An alternative arrangement is Model 105.

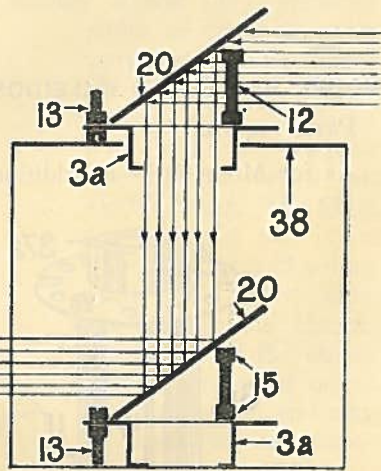

MODEL 103.

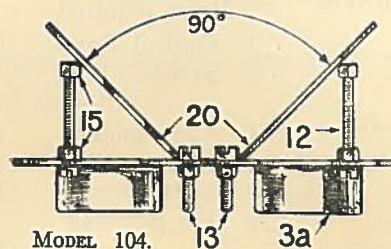

MODEL 104.

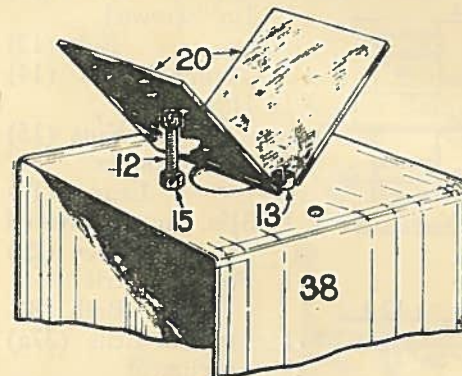

MODEL 105.

Look downwards into the Mirrors so that half of the face is seen in each. Move the Mirrors until the image of the nose is not distorted. Now close one eye, the "other eye" appears to close in the Mirrors. Place a printed card with the print facing one of the Mirrors, the print can be read in the other Mirror. Many other experiments may be carried out.

MODEL 106.—OPHTHALMOSCOPE.

Take a Square Mirror (20) and place a Plano - Convex Lens (18) with the flat side on the Mirror; the Lens

may be lightly stuck on if desired, with a little Canada Balsam.

Stand in a position where a strong light enters the eye, and hold the Ophthalmoscope close up. A highly magnified eye image will be seen, as well as some of the internal structure.

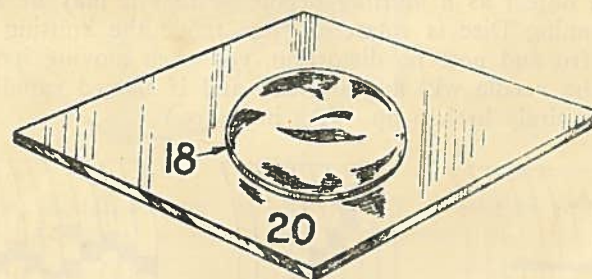

MODEL 106.

MODEL 107.—PICTURE SCANNER.

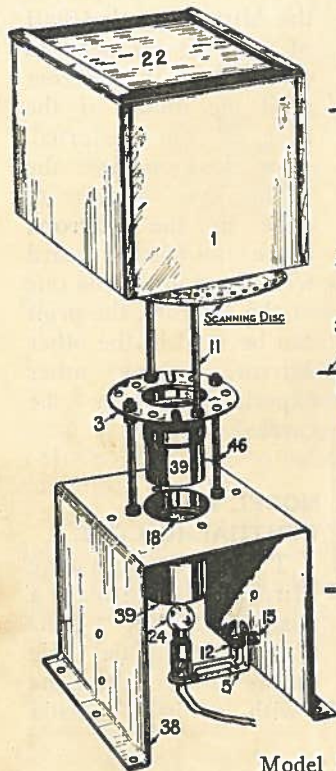

Model 107.

Directions for making which are to be found in the description of Model 89.

This Model may be used to show distortion of a projected image through a Scanning Disc. Project on to the Frosted Plate such an object as a knitting needle so that it may be seen as the Scanning Disc is rotated. Now move the knitting needle to and fro and note no distortion, yet when moving it up and down, the needle will appear bent, and if moved rapidly, will appear entirely broken up. (As in figure.)



Parts required:—

- | | | |
|----|----------------------|-------|
| 1 | Optical Box | (1) |
| 2 | Screwed Ring | |
| | Mounts | (3) |
| 1 | Lampholder | (5) |
| 1 | Distance Ring | (8) |
| 3 | Split Rings | (10) |
| 2 | 3in. Screwed | |
| | Rods | (11) |
| 1 | 1in. Screwed | |
| | Bolt | (12) |
| 5 | Terminal Nuts | (14) |
| 14 | Hexagonal | |
| | Nuts | (15) |
| 3 | Plano-Convex | |
| | Lenses | (18) |
| 1 | 3½in. Square Frosted | |
| | Glass Screen | (22) |
| 1 | Focus Electric | |
| | Bulb | (24) |
| 1 | Stop for Lens | (37a) |
| 1 | Instrument | |
| | Stand | (38) |
| 2 | Tubular Mounts | (39) |
| 2 | 2in. Screwed | |
| | Bolts | (46) |
| 1 | Scanning Disc | |

MODEL 108.—PROJECTION PICTURE SCANNER.

Parts required:—

- | | | |
|---|---------------------|-------|
| 1 | Optical Box | (1) |
| 2 | Screwed Ring Mounts | (3) |
| 1 | Lamp Holder | (5) |
| 2 | Split Rings | (10) |
| 3 | 1in. Screwed Bolts | (12) |
| 1 | Terminal Nut | (14) |
| 8 | Hexagonal Nuts | (15) |
| 3 | Plano-Convex Lenses | (18) |
| 1 | Focus Electric Bulb | (24) |
| 1 | Scanning Disc | |
| 1 | Stop for Lens | (37a) |
| 2 | Tubular Mounts | (39) |

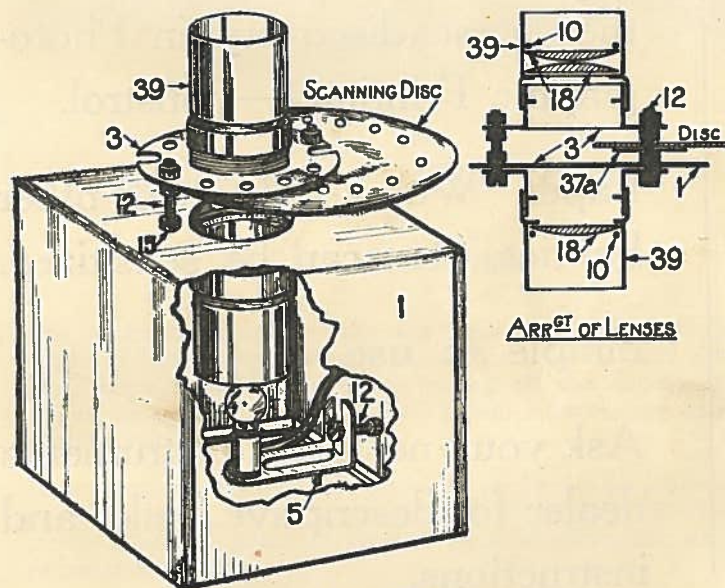

Model 108.

This Model is used for projecting an image through the Scanning Disc on a Screen in a dark room.

CONSTROL

PHOTOGRAPHERS!

Why not make your own Photographic Paper by using the latest discovery in Photographic Printing?—Constrol.

Paper, Wood, Silk and other Fabrics, etc., can be sensitized.

Simple to use.

Ask your nearest Construments dealer for descriptive leaflet and instructions.

Price 2/- per bottle.

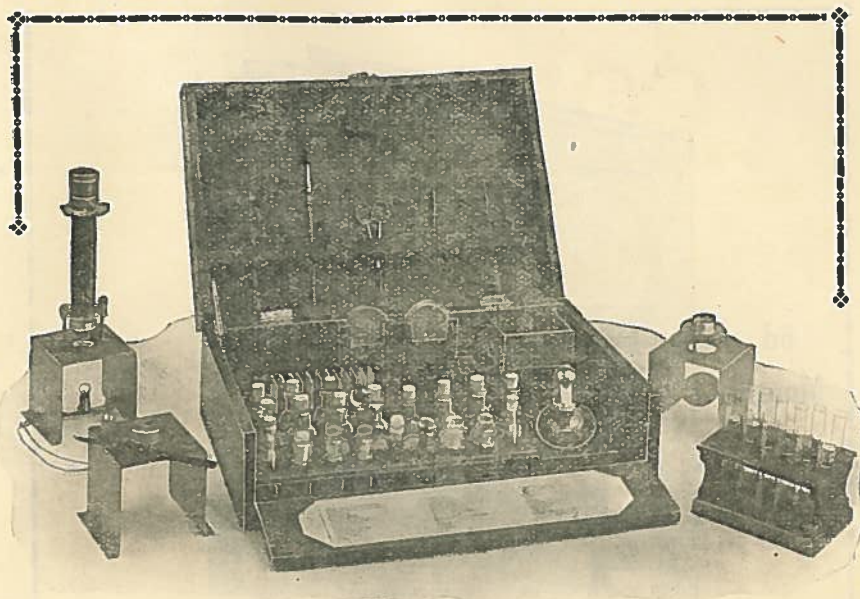

Construments Educational Biological Set.

For those wishing to take up this most fascinating study of living organisms, Construments Biological Set provides a complete outfit including all the necessary stains, re-agents, high and low power microscope and section cutter.

It is compact and portable and will be found invaluable to the student, as well as to those who take up this study from the point of view of general education and recreative science.

Price Complete 3½ guineas.

In Stout Wooden Box.

6d.
Monthly



6d.
Monthly

THE CONSTRUMAG

THE OFFICIAL JOURNAL OF INSTRUMENTS.

This Magazine presents, each month, many new and interesting uses of Instruments Models; will keep you informed of all new developments, new experiments, and a thousand-and-one things which are arising out of this unique "Hobby of Ten Thousand Thrills."

Never before has a magazine like this been published. It is coming in an age when everybody, young and old alike, is keener on scientific subjects and scientific knowledge than ever before in history.

Popular, bright, educative, informative, and profusely illustrated, the *Construmag* will be hailed with delight by every Boy and Girl of suitable age, and will also come as a boon to Educational Authorities as a means of extending and improving our national system of education in science.

Monthly prizes and awards are offered for new ideas, suggestions, or inventions.

To be obtained from all Newsagents.

PRICE 6d. MONTHLY.