

**Instruction Book**

**Price 1/-**

# Construlements

**THE HOBBY OF TEN THOUSAND THRILLS**

REGD TRADE MARK

**How to make  
& How to use**  
GENUINE SCIENTIFIC  
OPTICAL & PHOTOGRAPHIC  
INSTRUMENTS

from **SIMPLE  
INTERCHANGEABLE  
PARTS**

SIGNALLING LAMPS  
TORCHES. MAGNIFIERS  
MICROSCOPES. LAMP STANDS  
SHADOWGRAPHS. PHOTO-SHADOWGRAPHS  
PINHOLE CAMERAS. LENS CAMERAS  
MIDGET CAMERAS. PHOTO COPIERS  
PHOTO-PRINTERS. DARK ROOM LAMPS  
PHOTO-MICROSCOPES. KALEIDOSCOPIES  
MAGIC LANTERNS. MICRO-PROJECTION APPARATUS  
WATCH PROJECTORS. REFLECTOSCOPES. EPIDIASCOPES



**Scores of different Instruments from the same parts.**

Copyright by **CONSTRUMENTS LTD.** 18, Gray's Inn Road, High Holborn, London, W.C.1

# Construments

## THE HOBBY OF TEN THOUSAND THRILLS

Construments Outfits consist of strongly-made and well-finished interchangeable parts, screws, lenses, etc., from which a large variety of actually working Projection, Photographic, Optical and Scientific Instruments, as well as scientific "toys," can be built up, affording endless entertainment, education and opportunity for experiment.

With a Construments Outfit you can make and actually use a whole range of different Instruments in the same evening. The parts are so simple that you can transform one instrument into another at a moment's notice. Or you can experiment with microscopes one day, shadowscopes the next, indoor photography the next, and so on in an unending variety—all from the same set of parts.

A very short study of the pages of this Instruction Book will show how simple it is to follow the directions given and to construct or dismantle any of the models in a few minutes.

Care should, however, always be taken to place the lenses in the proper positions, especially in the Photographic and Projecting apparatus, as a wrong use of lenses spoils the focus. (See page 34).

On the opposite page are listed a number of models which can be made from the "20" Outfit and the complete "100" Outfit.

Construments Outfits are complete, except for a 2-cell Dry Battery which is required for the illumination of many of the models. The price of the Construments Battery is 1s. extra.

For Photographic purposes, the user will naturally require the necessary material, chemicals, etc., just as he would if purchasing an ordinary camera. It should be noted that the Construments Optical or Camera Box takes cut film or glass negatives  $3\frac{1}{2}$  inches square—the ordinary magic-lantern size. Or photographic printing paper of the same size may be used for direct pictures in many cases, without using a glass photo-plate. Use plates, cut film, and paper specially prepared for Construments Ltd.

### THE "CONSTRUMAG" Magazine of Popular Home Science and Experiment.

It is impossible in the scope of this Instruction Book to do more than suggest the various uses of the instruments that can be built up and the endless entertainment that can be enjoyed.

A wonderful new kind of magazine, the "CONSTRUMAG," is therefore in preparation, which will give all sorts of interesting information each month, and readers of these pages are invited to send in their names and addresses so that we can advise them immediately this magazine is ready for publication.

# Instruments and Apparatus you can make with the Construments "100" Outfit

An Asterisk\* indicates those which can be made from the "20" Outfit alone  
The "100" Outfit consists of the "20" Outfit and the "Plus" Outfit together

- | Model No. |   | Model No. |  |
|-----------|---|-----------|--|
| *1.       | Electric Torch (Tubular Type).                            | 40.       | Pinhole Camera (for Transparent Objects).      |
| *2.       | Spot-light.   | *41.      | Lens Camera (Box Type).                        |
| *3.       | Signalling Lamp (Morse Code).                             | 42.       | " " " " (with Hood).                           |
| *4.       | " " " " (Hello Type).                                     | 43.       | Button-Hole-Picture Camera.                    |
| *5.       | Low Power Magnifier (Tripod Type).                        | 44.       | " " " " (2-lens Type).                         |
| *6.       | " " " " (4-leg Type).                                     | 45.       | Micro-Reducing Camera.                         |
| *7.       | " " " " (Box Type for Opaques).                           | 46.       | " " " " (for Photo Negatives).                 |
| *8.       | " " " " (Box Type for Transparencies).                    | 47.       | Photo Copier and Enlarger.                     |
| *9.       | " " " " (Illuminated Type).                               | *48.      | Electric Lamp Photo Printer.                   |
| *10.      | " " " " ( " " " " )                                       | 49.       | " " " " (Improved Type).                       |
| 11.       | " " " " Stand Type A.                                     | *50.      | Red Lamp for Dark Room.                        |
| 12.       | " " " " " " B.  | 51.       | Magic Lantern.                                 |
| 13.       | " " " " " " C.  | 52.       | Daylight Magic Lantern.                        |
| 14.       | " " " " " " D.  | 53.       | " " " " (Type 2).                              |
| 15.       | Medium Power Magnifier (Slide Type).                      | 54.       | Low Power Projection Microscope.               |
| 16.       | " " " " (Pocket or Desk Type).                            | 55.       | Medium Power " " "                             |
| 17.       | " " " " (4-leg Type).                                     | 56.       | High Power " " " "                             |
| 18.       | High Power Simple Microscope (Slide Type).                | 57.       | " " " " (Dark Room Type).                      |
| 19.       | " " " " (Pocket or Desk Type).                            | 58.       | Low Power Photo Microscope.                    |
| 20.       | " " " " (Pocket or Desk Type with Stage for slide).       | 59.       | Medium Power " " "                             |
| 21.       | Medium Power Dissection Microscope (Stand Type).          | 60.       | High Power " " "                               |
| 22.       | " " " " (Stand Type, with Reflector).                     | *61.      | Hand Kaleidoscope.                             |
| 23.       | High Power Simple Microscope (Stand Type with Reflector). | *62.      | Simple Magnifying Kaleidoscope.                |
| 24.       | High Power Simple Microscope (Stand Type, with Lamp).     | *63.      | Illuminated Kaleidoscope (Box Type with Lamp). |
| 25.       | High Power Compound Microscope (with Lamp).               | 64.       | " " " " (Stand Type with Reflector).           |
| 26.       | " " " " (with Reflector).                                 | 65.       | " " " " ( " " " with Lamp).                    |
| *27.      | Lamp Stand (Vertical Model).                              | 66.       | Reflection Kaleidoscope.                       |
| *28.      | " " " " (Horizontal Model).                               | 67.       | " " " " (For Projecting).                      |
| *29.      | Shadowscope (For Dark Room).                              | 68.       | " " " " ( " " " short distance).               |
| *30.      | Daylight Shadowscope.                                     | 69.       | Hand Micro-Kaleidoscope.                       |
| 31.       | Shadowscope (For Dark Room, with Reflector).              | 70.       | Stand Model Micro-Kaleidoscope.                |
| *32.      | " " " " (with Glass Stage).                               | 71.       | " " " " (High Power).                          |
| *33.      | Daylight Shadowscope (Vertical Model).                    | 72.       | Tele-Kaleidoscope.                             |
| *34.      | Photo Shadowgraph.  | 73.       | Reverse Tele-Kaleidoscope.                     |
| 35.       | Shadowscope (for Dark Room, Downward Throw).              | 74.       | Projection Kaleidoscope.                       |
| 36.       | Photo Shadowgraph (Downward Throw).                       | *75.      | Photo-Kaleidoscope.                            |
| *37.      | Camera Obscura (Toy Model).                               | *76.      | Watch Projector.                               |
| *38.      | Pinhole Camera (Box Type).                                | 77.       | " " " " (Photo Type).                          |
| 39.       | " " " " (Midget Type).                                    | *78.      | Epidiascope.                                   |
|           |   | *79.      | Reflectoscope.                                 |
|           |   | 80.       | Periscope (Toy Model).                         |
|           |   | 81.       | Astronomical Telescope (Model).                |

# How Construments Outfits are Sold

## THE CONSTRUMENTS "20" OUTFIT.

Makes from interchangeable parts £20 worth of Pin-hole and Lens Cameras, Magnifiers, Electric Lamps, Lamp Stands, Photo-printers, Dark-room Shadowgraphs, Hand, Magnifying and Illuminated Kaleidoscopes, Photo-copiers and Enlargers, Epidiascopes, Watch Projectors, Signalling Lamps, Torches, Model Periscopes, etc. For full list, see previous page ... .. 18/6

*Ask at the same time for a Construments 2-cell Dry Battery, 1/- extra.*

## THE CONSTRUMENTS "PLUS" OUTFIT.

This Outfit is accessory to the "20," converting it into the "100" Outfit described below. It includes an Instrument Stand, High Power and other Lenses, and parts supplementary to the "20" Outfit. 21/-

## THE CONSTRUMENTS "100" OUTFIT.

**Consists of the "20" and the "Plus" Outfits together.**

Makes from interchangeable parts £100 worth of Instruments, not only Improved and more powerful versions of those in the "20" Outfit, but also Compound and High Power Microscopes, Photo-microscopic Apparatus, Midget Cameras, Daylight Magic Lanterns, Projection Microscopes, Reflection Kaleidoscopes, Astronomical Telescope, etc. For full list, see previous page ... .. 37/6

*Ask at the same time for a Construments 2-cell Dry Battery, 1/- extra.*

Any of the parts shown in pages 5 to 10 may be purchased separately. Be careful, when ordering, to mention the Identification Number to avoid error.

## Ready Shortly

## THE CONSTRUMENTS DE LUXE OUTFIT.

Including a wonderful "Portable Dark Room" for loading, developing, fixing, etc. In this magnificent set will be included not only the full Construments "100" Outfit with all the parts set out in a beautiful compartmented tray, but also a complete "studio" of Day or Night "easy-as-a.b.c." Photographic Outfit, Standard Developer, Hypo, Dishes, Paper, Cut Film, Electric Battery, etc., made especially for Construments Ltd. ... .. 84/-

*Absolutely complete. No Battery to buy.*

## PORTABLE DARK ROOM ONLY.

Which you can use for loading, developing, fixing, etc., either by day or night without red lamps. Takes not only Construments "Home-made Cameras," but also other small size cameras. (Provisional Price) ... .. 42/-

*A great boon to all-year-round photography.*

**CONSTRUMENTS LTD., 18, Gray's Inn Road, LONDON, W.C.1**

*(Telephone and Telegrams : Holborn 1797)*

# How to identify your CONSTRUMENTS Parts

The following (Nos. 1 to 37) will be found in the  
"20" OUTFIT (makes £20 worth of Instruments and Apparatus)

The prices shown are those of the parts if bought  
separately.

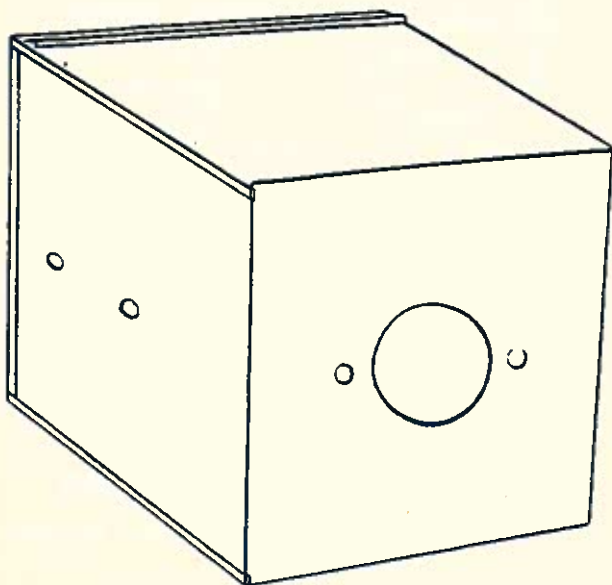

**No. 1. OPTICAL BOX.**

Shown half actual size. This is also used as a  
Camera in the Photographic Models. Price 3/-

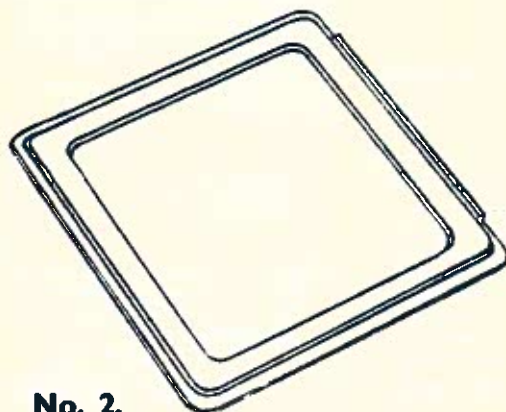

**No. 2.  
LID FOR OPTICAL BOX.**  
(Shown half size.)  
Price 1/-

**No. 3.  
RING  
MOUNT.**  
(Shown  
in actual  
size.)

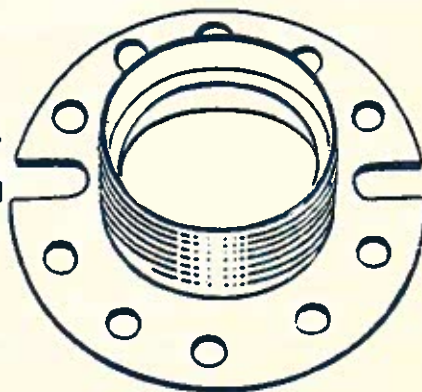

Price  
2/-

**No. 4.  
OPTICAL  
TUBE.**

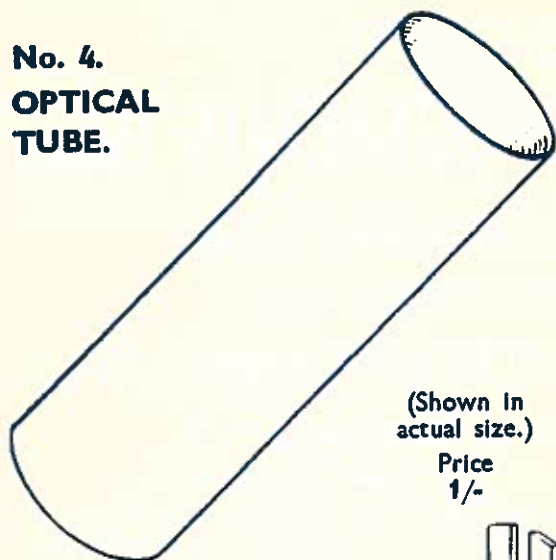

(Shown in  
actual size.)  
Price  
1/-

(Actual size.)  
Showing fixed  
connections  
of flex, the  
other ends  
of which are  
connected to  
the battery.  
Price 1/3

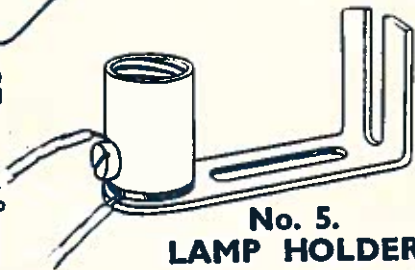

**No. 5.  
LAMP HOLDER**

**No. 6.  
CAMERA CAP.**

Price 1/-



**No. 7.  
BATTERY  
CLIP.**

(Showing how  
the bare end of  
the wire is  
gripped by being  
passed through  
centre.)  
Price 4d.

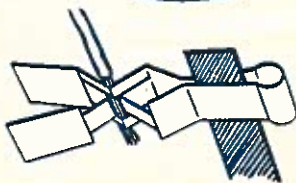

First insert battery terminal in spring end of clip as shown. Then squeeze opposite ends of clip to make room for the wire to be passed through at the waist.



**No. 8.  
DISTANCE RING.**  
(Actual size.)  
Price 2d.



**No. 9.  
SMALL-PINHOLE  
DISC.**  
(Actual size.)  
Price 6d.

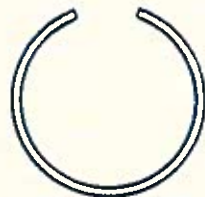

**No. 10.  
SPLIT RING.**  
(Actual size.)  
Price 1d.



**No. 11. 3-inch SCREWED ROD.**  
(Actual size.) Price 3d. each.



**No. 12. 1-inch  
SCREWED BOLT.**  
(Actual size.) Price 6d. doz.



**No. 13. 1/2-inch  
SCREWED BOLT.**  
(Actual size.) Price 6d. doz.



**No. 14. TERMINAL NUT.**  
(Actual size.) Price 6d. per doz.



**No. 15. HEXAGONAL NUT.**  
(Actual size.)  
Price 3d. per doz.



**No. 16. COMBINED  
SPANNER SCREWDRIVER.**  
(Actual size.) Price 3d.



**No. 17. BI-CONVEX  
LENS.**

(Actual size.)

Note that the Bi-Convex  
Lens has a slight curve both  
sides.

Price 2/-



**No. 18. PLANO-  
CONVEX LENS.**

(Actual size.)

Note that the Plano-Convex  
Lens is flat on one side and  
curved on the other.

Price 2/6

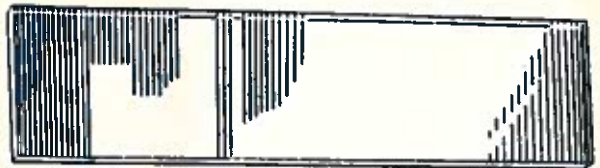

**No. 19. STRIP MIRROR.**  
(Actual size.) Price 2d.



**No. 20.  
SQUARE  
MIRROR.**  
(Shown three-  
quarter size.)  
Price 3d.

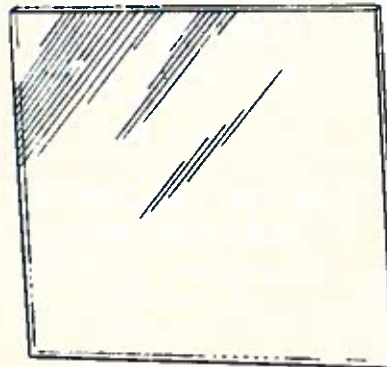

**No. 21.  
3¼-inch  
SQUARE  
GLASS  
PLATE.**  
(Shown half-  
size.)  
Price 2d.

Many of these parts are duplicated in the Construments "Plus" Outfit. The "20" and the "Plus" Outfits together comprise the "100" Oufit.

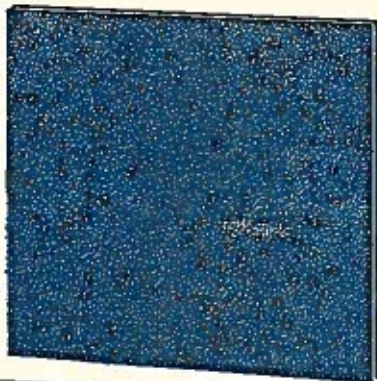

**No. 22.**  
**3 $\frac{1}{4}$ -inch**  
**SQUARE**  
**FROSTED**  
**GLASS**  
**SCREEN.**

(Shown half-size.)  
 Price 3d.



**No. 23. GLASS SLIDE.**  
 (Actual size.) Price 1d.



**No. 24. FOCUS**  
**ELECTRIC BULB.**

Note that the glass is transparent.  
 Price 6d.



**No. 25. BI-CONVEX**  
**ELECTRIC BULB.**

Note that the glass is solid in appearance.  
 Price 9d.

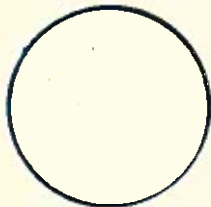

**No. 26.**  
**1-inch FROSTED**  
**DISC.**

(Actual size.)  
 Price 1d.



**No. 27. RED**  
**TRANSPARENT**  
**DISC.**

(Actual size.)

**No. 28** is as above but Yellow.  
**No. 29** " " Green.  
**No. 30** " " Blue.

Price 1d. each.



**No. 31.**  
**SMALL RED**  
**OPAQUE DISC.**

(Actual size.)

**No. 32** is as above but Yellow.  
**No. 33** " " Green.  
**No. 34** " " Blue.  
**No. 35** " " White.  
**No. 36** " " Black.

Price  $\frac{1}{2}$ d. each.



**No. 37.**  
**RUBBER BAND.**

(Actual size.)

Price 3d. per doz.

The Parts Numbers shown on pages 5 to 10 are given in order to make it easy for you to identify each item. They are quoted also in the "Fitment" Diagrams. When ordering extra or spare parts these numbers should always be given in order to avoid mistakes.



# The following extra parts (Nos. 38 to 47) will be found in the **CONSTRUMENTS "PLUS" OUTFIT**

(converting the "20" Outfit into the "100" Outfit, which makes £100 worth of Instruments and Apparatus).

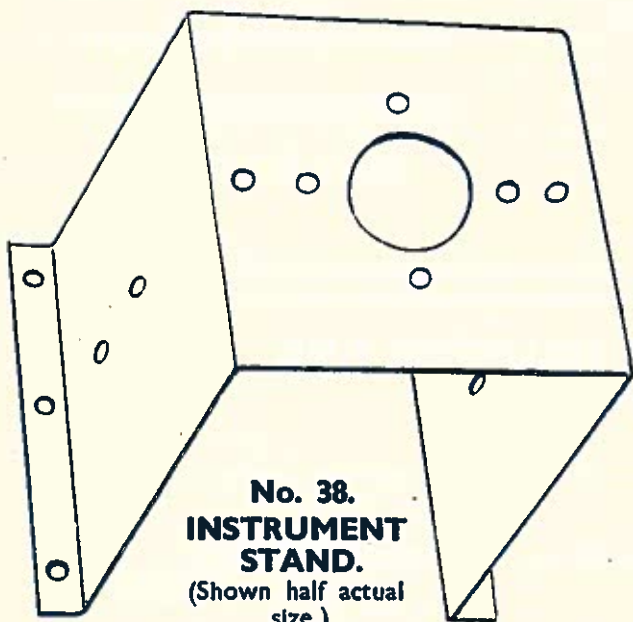

**No. 38.  
INSTRUMENT  
STAND.**

(Shown half actual size.)

Price 2/-



**No. 40.  
TUBULAR  
MOUNT CAP.**

(Actual size.)

Price 6d.

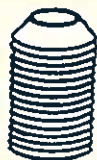

**No. 41. HIGH-POWER  
OBJECTIVE.**

(Actual size.)

Price 2/6

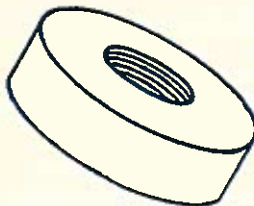

**No. 41a.  
MOUNT for  
HIGH-POWER  
OBJECTIVE.**

(Actual size.)

Price 1/-

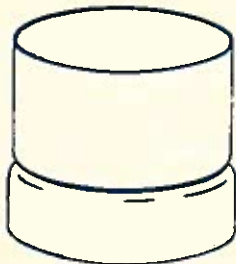

**No. 39.  
TUBULAR  
MOUNT.**

(Actual size.)

Price 1/6

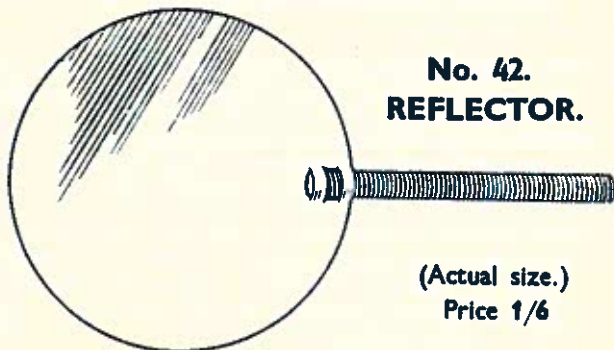

**No. 42.  
REFLECTOR.**

(Actual size.)

Price 1/6



**No. 43. SPRING CLIP.**  
(Actual size.) Price 1d.



**No. 45. LARGE-PINHOLE DISC.**  
(Actual size.)  
Price 6d.



**No. 44. STOP FOR LENS.**  
(Actual size.)  
Price 3d.

**No. 46.**  
**2-inch SCREWED BOLT.**



(Actual size.) Price 1d.



**No. 47. GLASS COLLECTING TUBE.**  
(Actual size.) Price 1d.

---

### Useful Hints for Assembling Construments Units.

**SPLIT RINGS.**—Insert ends first and squeeze down the opposite side with the end of a pencil or other convenient object until the split-ring "sits" tight up against the lens, disc or other part which you are using.

**LAMPS.**—The Electric Lamp bulb should always be centred accurately so that it looks exactly into the middle of the optical hole in the Box or Stand.

**CAMERA CAP.**—When using the Camera Cap over a Ring-Mount do not press right down over the screwed thread as this tends to fray the plush inner band. Just tip on and remove with a slight screwing motion instead of a direct pull.

**CAMERAS.**—Be sure to stop up the side holes of the Optical Box with  $\frac{1}{2}$ -inch screwed bolts in order to exclude the light. Focus for distance and clearness of image on the ground-glass screen before inserting plate or film. The ground-glass screen should always be placed with the frosted side nearest the lens. See also Photographic Hints, page 34, and Notes on Midget and Button-Hole-Picture Cameras, page 35.

# A Few Simple "Fitments"

**With Construments Parts, Screws and Lenses. To show you how easy it is to put together the various Models and Apparatus.**

The following are given as examples of the methods used in building up the various instruments. A very little practice with these "Fitments" will enable you to become fully familiar with every part and its purpose and also to construct from the drawings, in the great majority of cases, any of the Models illustrated on page 16 and onwards, without referring back to these Fitments. The numbers of the parts given are the same as those on pages 5 to 10.

The combined Spanner-Screwdriver (No. 16), supplied with the "20" Outfit, will enable you to tighten up any nuts or bolts if need be, though most operations can be done with the fingers alone.

If a Construments 2-Cell Dry Battery (price 1/-) is used for illumination, a firm and easy contact is made by using the special Battery Clip (No. 7) which grips the bare-wire end of the flex and at the same time grips the flat terminal ends of the Battery. (See page 6, No. 7).

## FITMENT No. 1

**How to Insert a Lens or Disc into a Ring Mount (No. 3).**

**Position A.** Simply place Lens or Disc inside ring-mount, as shown in diagram alongside.

**Position B.** —Or in the other side of the ring-mount, as in the lower picture.

Then fix lens in position by squeezing one of the Split Rings (No. 10), and pressing into position as shown.

**N.B.** Discs, Lens-stops or other attachments, according to needs, are mounted in the ring-mount in exactly the same way—a matter of two seconds only.

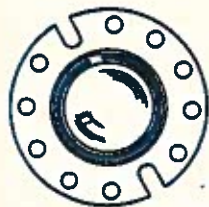
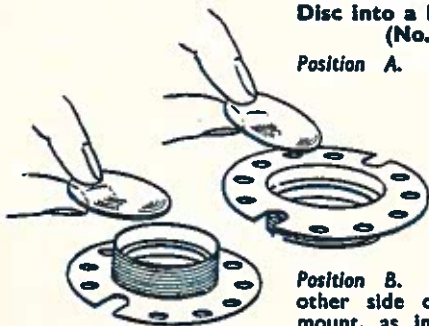

## FITMENT No. 2

**Inserting a Lens or Disc into a Tubular Mount (No. 39) or Tubular Mount Cap (No. 40).**

Proceed exactly as in Fitment No. 1 by simply dropping the lens, disc or stop into position and securing down on to the lens to keep it from moving.

Top picture shows the Tubular Mount.

Lower picture shows the Tubular Mount Cap.



## FITMENT No. 2a

**Ramsden Eye-piece—Arrangement of Lenses.**

Put one Plano-convex Lens (No. 18) into the Tubular Mount, as shown above, with the curved side of the lens upwards. Put another of No. 18 into the Cap in the same way. Secure both with split rings. Now fit the Cap on to the Tubular Mount. There will thus be an eye-piece containing two lenses with their curved sides inwards. This is known as a Ramsden Eye-piece. (See diagram overleaf).



The diagram alongside shows the lenses in position for the Ramsden Eye piece.



## FITMENT No. 3

Attaching a Ring-Mount (No. 3) to the Optical Box (No. 1).

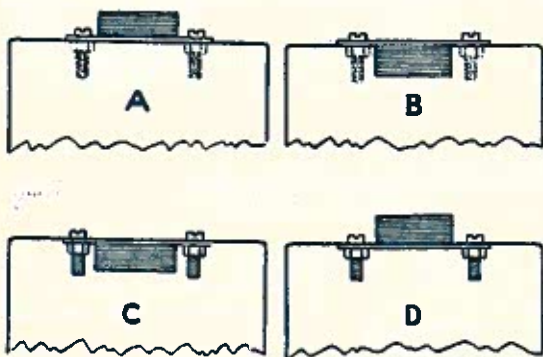

Place the Ring Mount over the large centre hole of the Optical Box and secure by means of two half-inch bolts (No. 13) and Hexagonal Nuts (No. 15).

The pictures above are sectional views showing :—

- Position A. Ring-Mount right way up.
- Position B. Ring-Mount upside down with its screwed part projecting downwards through the centre hole of the Optical Box.
- Position C. Ring-Mount upside down, but placed over the central hole of the Optical Box from inside the box.
- Position D. Ring-Mount projecting upwards through centre hole of Optical Box from the inside of the box.

N.B.—The screwed bolts may be projecting into the box as shown, or placed the other way up and secured by nuts from outside if desired.

N.B.—It will be seen that the above mounts give four different positions for lenses. These should be noted when using the Optical Box as a camera.

## FITMENT No. 4

Attaching Screwed Bolts (Nos. 12, 13 or 46) to the Optical Box (No. 1) or the Instrument Stand (No. 38)

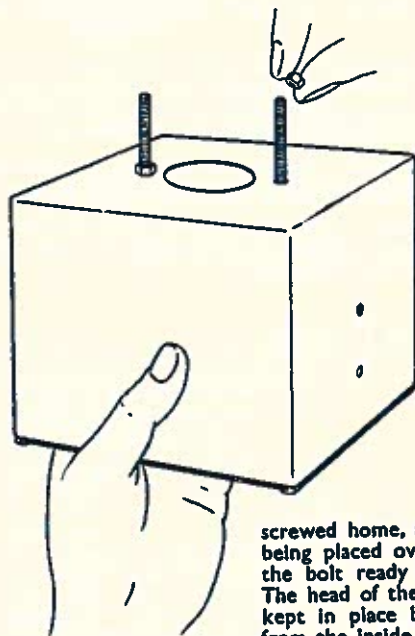

Push the bolts through the holes on either side or the large centre hole and secure by means of a Hexagonal Nut (No. 15) or a Terminal Nut (No. 14). The picture shows one of the nuts already

screwed home, and the other being placed over the top of the bolt ready to screw on. The head of the bolt is being kept in place by the fingers from the inside of the box.

## FITMENT No. 5

Attaching Screwed Rods (No. 11) to the Optical Box (No. 1) or the Instrument Stand (No. 38).



It will be noticed that the screwed rods differ from the bolts in having no fixed head. Therefore a hexagonal nut must first be screwed on for a few turns before inserting in the holes.

The picture alongside shows one of the screwed rods in position and the other, with nut attached, being inserted into the other hole.

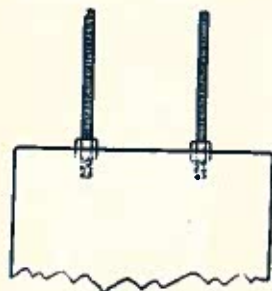
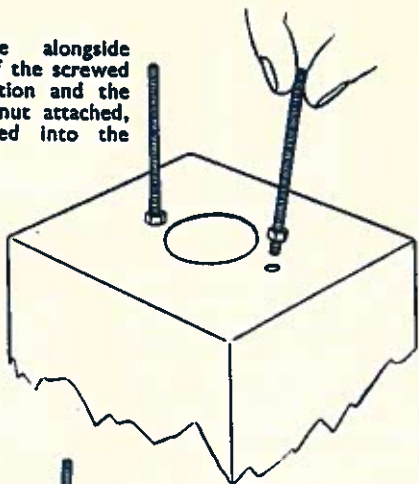

This picture shows how the screwed rods are held firmly in place by means of two other hexagonal nuts put on from the underside of the Optical Box or the Instrument Stand.

## FITMENT No. 6

Mounting the Optical Tube (No. 4) between two Ring-Mounts (No. 3).

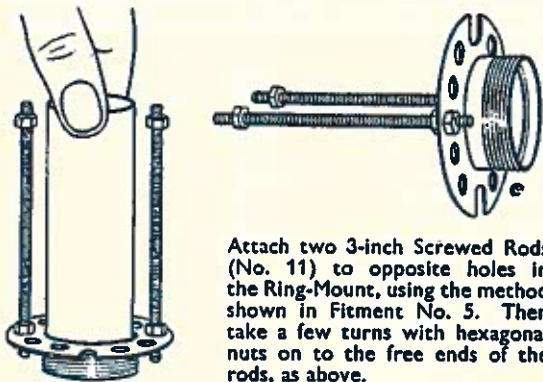

Attach two 3-inch Screwed Rods (No. 11) to opposite holes in the Ring-Mount, using the method shown in Fitment No. 5. Then take a few turns with hexagonal nuts on to the free ends of the rods, as above. Next place the Optical Tube in position as shown alongside.

Complete this Fitment by placing another Ring-Mount over the free ends of the screwed rods so that it rests on the two nuts you have just put a little way on. Now secure as shown alongside with two more nuts. You will see that eight nuts are used in all.



## FITMENT No. 7

Mounting the Lamp-Holder (No. 5) to the Optical Box (No. 1) or the Instrument Stand (No. 38).

Take a 1-inch Screwed Bolt (No. 12) and clamp it to the bracket of the Lamp-holder by means of a hexagonal nut as shown. Screw up tight with the aid of the Spanner (No. 16).

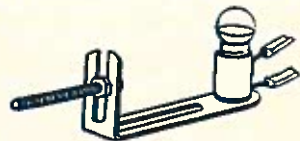

Now take a few turns of another hexagonal nut on to the free end of the bolt and push this free end through the central hole in the side of the Optical Box or Stand from inside.

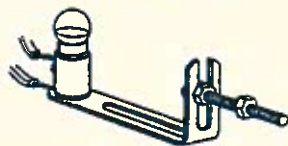

You will then see the free end of the bolt projecting from the box.

Secure by means of a hexagonal nut screwed on to the free end of the bolt from the outside.

The spacing of the nuts must be arranged so that the lamp bulb is directly central under the

large centre hole of the Box or Stand.

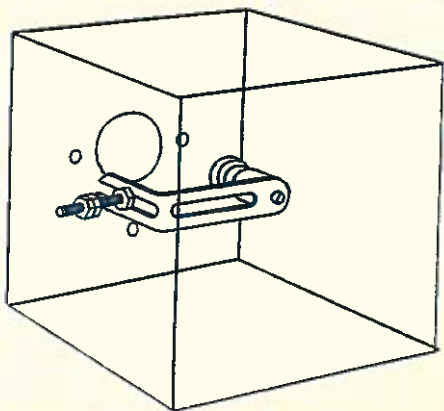

## FITMENT No. 8

Another Method of Mounting the Lamp-holder (No. 5) by means of a 3-inch Screwed Rod (No. 11).

Proceed exactly as in Fitment No. 5, but secure the Screwed Rod to the bracket of the Lamp-holder by means of two hexagonal nuts, as shown.

Then put another nut on to the free end of the rod, ready for attaching.

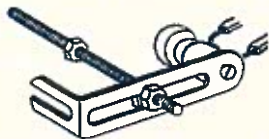

## FITMENT No. 9

Mounting the Lamp-Holder (No. 5) inside the Instrument Stand (No. 38).

Use a 1-inch Screwed Rod and two hexagonal nuts as in Fitment No. 7, and secure from the outside of the Stand by means of a Terminal Nut (No. 14) as shown.

Position A indicates the lower hole.

Position B indicates the central hole in the side of the Stand.

Note the spacing of the nuts to bring the lamp bulb into dead centre with the large hole in the top of the Stand.

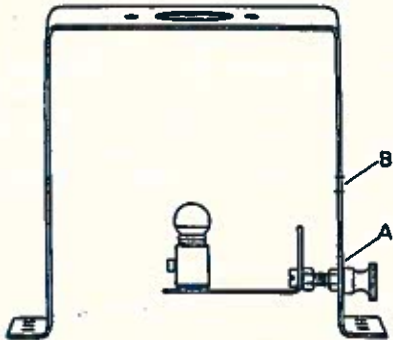

## FITMENT No. 10

Constructing a Mirror-Stand.

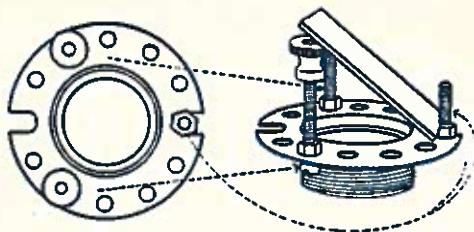

Above, TYPE 1.

Made from a Ring-Mount (No. 3), two 1-inch Screwed Bolts (No. 12), one  $\frac{1}{2}$ -inch Screwed Bolt (No. 13), two Terminal Nuts (No. 14) and three Hexagonal Nuts (No. 15). Place the Mirror (No. 20) with the glass side downwards.

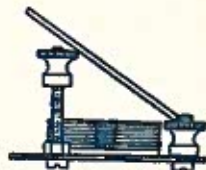

Centre, TYPE 2.

As above, but with the Ring-Mount the other way up, and with a Terminal Nut on the  $\frac{1}{2}$ -inch Screwed Bolt in order that the Mirror is raised above the screwed collar of the Ring-Mount.

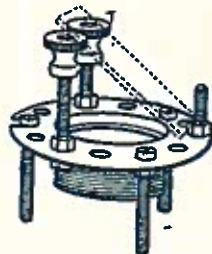

On right, TYPE 3.

Exactly as Type 1 but standing on three "legs" made by placing 1-inch Screwed Rods in the holes shown and securing by means of hexagonal nuts.

## FITMENT No. 11

To fix a Ring-Mount (No. 3) at a distance from the Optical Box (No. 1) or the Instrument Stand (No. 38).

Fix two 3-inch Screwed Rods as in Fitment 5, and take a few turns with hexagonal nuts on to the free ends of the Rods as shown in the picture alongside.

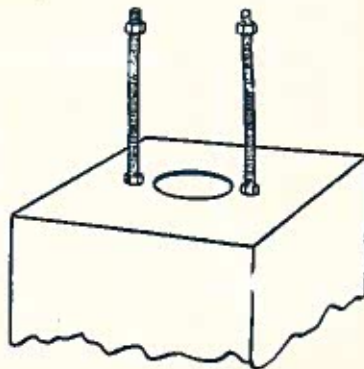

Rest the Ring-Mount on these two hexagonal nuts and fix with two more as shown here. The distance of the Ring-Mount from the top of the Box or Stand can easily be adjusted, as can be seen.

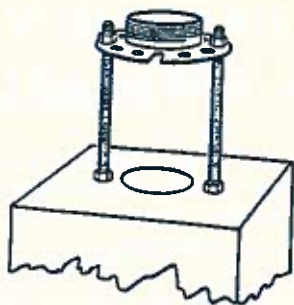

## FITMENT No. 12

**Mounting the Lamp-holder (No. 5) flush with Inside Wall of the Optical Box (No. 1).** Mount by means of a  $\frac{1}{2}$ -inch Screwed Bolt (No. 13) to one of the holes in the side of the Optical Box as shown, and thread the free ends of the flex through the other hole ready for connecting up to the Battery.

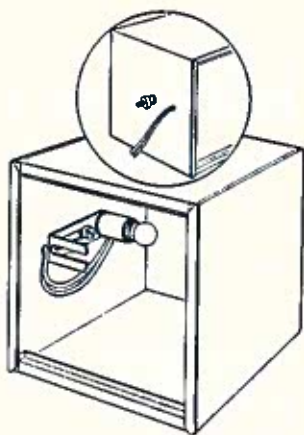

## FITMENT No. 13

**Fixing the High-Power Objective (Nos. 41 and 41a) to a Ring-Mount (No. 3).**

*Position A* (on the left) shows the High Power Objective with its lens pointing upwards. Screw into its Mount (No. 41a) as indicated, and then screw the Mount on to the Ring-Mount.

*Position B* (on the right) shows the High-Power Objective with its lens pointing downwards.

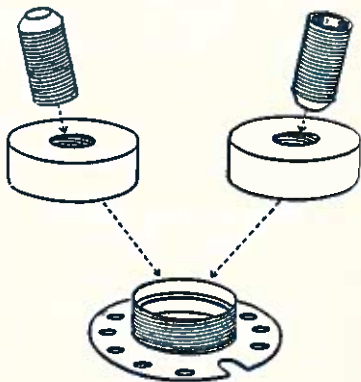

## FITMENT No. 14

**Fixing the Reflector (No. 42) to the Instrument Stand (No. 38).**

First screw a Terminal Nut (No. 14) a little way along the rod of the Reflector.



Insert through hole in the side of the Stand and secure by means of another Terminal Nut from the outside.

The centre hole as shown, is called *Position A*.

*Position B* indicates mounting the Reflector through the lower hole, which, in some cases, gives better illumination.

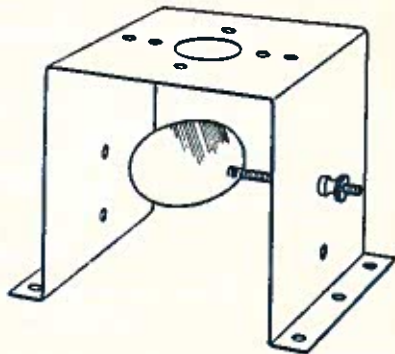

## FITMENT No. 15

**How to Fix Spring Clips (No. 43) for holding Microscope or other Slides to the Instrument Stand (No. 38) or the Optical Box (No. 1).**

Spring Clips should be mounted as shown and secured in position by means of the same hexagonal nuts that hold the Screwed Rods or Bolts in place. To insert slide lift up the free ends of the clips with the finger-tip.



# HOW TO PUT TOGETHER THE VARIOUS INSTRUMENTS & APPARATUS

In most cases the reader will be able to assemble any of the Instruments shown, simply on sight of the diagrams. To make everything as clear as possible, however, references are made back to the various "Fitments," which are featured on pages 11 to 15. These should be consulted in order to make sure that the parts, lenses, etc., are in their correct positions.

There is ample scope for experiment in Constructions, and users should try various arrangements and novelties of their own.

## MODEL No. 1

### Electric Torch (Tubular Type)

Mount the Optical Tube between two ring-mounts as shown (Fitment No. 6) and mount the Lamp Holder as in Fitment 8, but using a 1-inch screwed bolt instead of the 3-inch screwed rod. Care should be taken to tighten up all nuts so that the lamp is held rigidly in place in the centre of the tube, and not touching the sides. The lamp used must be the Focus Electric Bulb (No. 24), and not the Bi-Convex type. When you have assembled the Instrument, insert a Bi-Convex lens (No. 17) into the ring-mount farthest away from the Lamp and secure with a split ring as in Fitment No. 1. Connect up the wires of the lamp-holder with the Battery, and you have a torch with a penetrating beam. Coloured discs (Nos. 27 to 30) may be put over the lens to secure coloured light-rays.

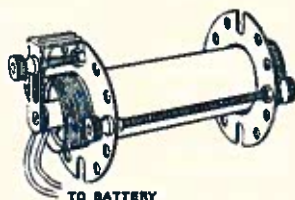

## MODEL No. 2

### Spot Light

Insert the lamp and lamp-holder in the back hole of the Optical Box by means of a 1-inch screwed bolt as in Fitment No. 7, and thread the loose ends of the wires through the other hole ready for attaching to the battery. The ring-mount in the centre contains a Bi-Convex Lens (No. 17). Coloured discs Nos. 27 to 30 may also be used behind the lens and secured by a split ring.

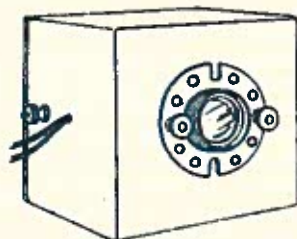

## MODEL No. 3

### Signalling Lamp (Morse Code)

Attach a Ring-mount (No. 3) at a little distance from the under side of the Optical Box by means of 3-inch screwed rods (No. 11), as shown in the picture. Then mount the Optical Tube (No. 4) as shown, between the lower and the upper Ring-mount. Place a Bi-Convex Lens (No. 17) in the upper Ring-mount and secure by means of a split ring. The Focus Electric Bulb and the Lamp-holder are mounted as in Model No. 1, but in the central hole of the Optical Box, so that the lamp looks directly up the Optical Tube (see picture). To flash dots and dashes connect the bare end of one of the wires to the battery by means of the battery-clip and touch the other battery terminal with the bare end of the second wire, thus making momentary contacts long or short.

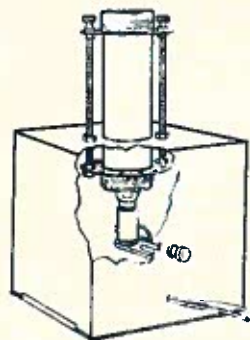

## MODEL No. 4

### Signalling Lamp (Helio. Type)

This is built up exactly as Model No. 3, but has, in addition a mirror (indicated A in the diagram alongside) mounted on a Stand as in Fitment No. 10, so that the light may be reflected horizontally in long or short flashes. Fitment No. 10 shows how to make the mirror-holder.

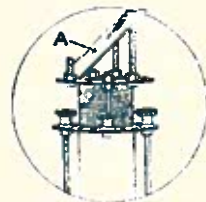



# Low Power Magnifiers

## MODEL No. 5

Low Power Magnifier.  
(Tripod Type.)

Insert a Plano-convex Lens (No. 18) in a Ring-mount with the curved side upwards; secure by a split-ring, and mount on three 1-inch screwed bolts (No. 12). This can then be placed on the object to be viewed. Useful for stamps, pictures, grasses, etc., where more detail is needed without high magnification.

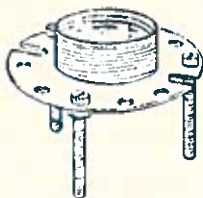

## MODEL No. 6

Low Power Magnifier  
(4-leg Type.)

As Model No. 5, but mounted on four screwed bolts, one in each of the holes in the Ring-mount which are next to the slots. In this way slides can be placed between the legs of the Magnifier.

## MODEL No. 7

Low Power Magnifier  
(Box Type, for  
Opaque Objects)

Insert Plano-convex Lens in Ring-mount as in Model No. 5, and mount on two 1-inch screwed bolts as shown. The top of the Optical Box can thus be used as a stage for supporting the objects to be viewed.

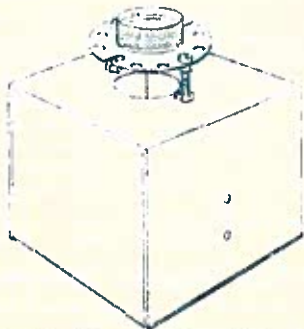

LOW POWER MAGNIFIERS, as their name implies, must not be expected to give a high degree of magnification, but they are useful in a score of ways, and give particularly good results when illuminated.

## MODEL No. 8

Low Power Magnifier.  
(Box Type with Lamp.)

Use a Bi-convex Lens this time (No. 17), and mount on the Optical Box by means of the two 3-inch screwed rods (No. 11), as in Fitment No. 11. The distance between the lens and the top of the Optical Box should be 2 inches. Now fix the Focus Electric Bulb (No. 24) by means of the Lamp-holder as in Fitment No. 7, but to the lower hole of the Optical Box and thread the free ends of the wires through the centre hole as shown, ready for attaching to the battery. A powerful light from below is thus thrown upon semi-transparent objects that you wish to view. For transparent objects that fit a Ring-mount to the under-side of the Optical Box as shown in Model No. 3, attaching it to the ends of the screwed rods before screwing on the lower nuts. You can then secure a softer diffused light by dropping the Frosted Disc (No. 26) into the ring-mount and securing by a split-ring. Alternatively, coloured Discs (Nos. 27 to 30) may be used to give a contrasting illumination of, for instance, whitish objects.

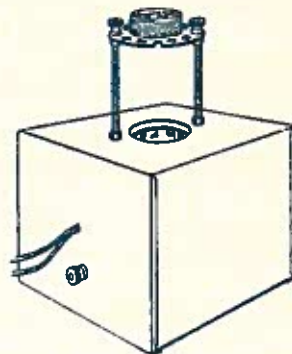

## MODEL No. 9

Low Power Magnifier  
(Box Type A.)

Proceed as in Model No. 8, but mount a Plano-convex Lens with the curved side upwards and use 1-inch screwed bolts (No. 12) instead of 3-inch screwed rods. You will note that a Plano-convex Lens is always mounted nearer to the object than the Bi-convex Lens, owing to its shorter focal length.

## MODEL No. 10

(Box Type B.)

Construct as Model No. 7, but use lamp illumination and Frosted Disc (No. 26) as in Model No. 8).

## MODEL No. 11

(Stand Type A.)

The Lens is mounted exactly as in Model No. 7, but on the Instrument Stand (No. 38) instead of the Optical Box.

## MODEL No. 12

(Stand Type B.)

The Lens is mounted exactly as in Model No. 8, but on the Instrument Stand (No. 38) instead of the Optical Box.

## MODEL No. 13

(Stand Type C.)

This is as Model No. 11, but using the Reflector (No. 42), as in Fitment No. 14, instead of the Focus Lamp for illumination.

## MODEL No. 14

(Stand Type D.)

This is as Model No. 12, but using the Reflector (No. 42), as in Fitment No. 14, instead of the Focus Lamp for illumination.

**NOTE.**—In the above four Models (Nos. 11 to 14), it is interesting to try either the Lamp or the Reflector in the centre or the lower holes in the side of the Instrument Stand and according to the degree of illumination required. The Reflector may also be tried with the white side or the polished side uppermost.

## Medium Power Magnifiers

### MODEL No. 15

(Slide Type.)

Take two Plano-convex Lenses (No. 18). Drop the first one, curved side upwards, into the Tubular Mount (No. 39) as in Fitment No. 2. Then insert the Distance Ring (No. 8), and drop in the second lens, curved side downwards. Secure by means of a split-ring (No. 10). You will then have the lens position as shown in the circle. Now fit on the Tubular Mount Cap (No. 40) and screw



the assembly on to a Ring-Mount (No. 3) as shown.

This is a very useful type of Magnifier for placing directly upon micro-slides, photo-negatives, etc. By holding them up to the light with the Magnifier in position, you can view any part of the slide or negative with very satisfactory detail.



## MODEL No. 16

(Pocket or Desk Type).

A very useful model for those who wish to examine process blocks, prints, fabrics, and various samples. Can also be used as a desk paper-weight. Proceed exactly as in Model No. 15, except that the lenses, owing to their increased distance from the object, should be arranged as shown above, but mount as a tripod on three  $\frac{1}{2}$ -inch screwed bolts. Model No. 5 shows how bolts are inserted at equal distances.



## MODEL No. 17

(4-Leg Type with Stage.)

Lenses are arranged exactly as in the previous model, but this time two Ring-Mounts (No. 3) are used, with four 1-inch screwed bolts (No. 12) in the positions shown. Note three hexagonal nuts (No. 15) to each screwed bolt. The space between the Ring-mounts forms a convenient stage for microscopic slides, for fingerprints, which you can impress on a glass slide (No. 23) or for your own "home-made" slides. (See page 33.)

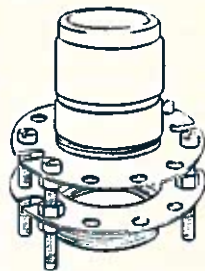

## High Power Simple Microscopes

The following three Models are made by using the High-Power Objective (No. 41) screwed lens downwards as in Fitment No. 13, Position B, into the Mount (No. 41a)—the whole being then screwed to a Ring-mount (No. 3) as shown in the first picture below. Note that the field of view, though small, gives a high magnification, and only very tiny objects can be seen all at once. Note also that the High-Power Objective must be very close to the object. You get the right focus by screwing the Objective or the Mount either up or down.

### MODEL No. 18

#### High Power Simple Microscope

(Slide Type.)

This is used for placing directly upon a microscopic slide and then holding both slide and magnifier up to the light, with the eye very close to the hollow end of the objective (No. 41).



## MODEL No. 19

### High Power Simple Microscope (Pocket or Desk Type.)

This is the same as Model No. 18, but mounted on four  $\frac{1}{2}$ -inch screwed bolts (No. 13) inserted in the four holes of the Ring-mount on either side of the slots. (Model No. 17 shows this position of the bolts.) This again is for viewing microscopic slides, which should be placed between the four legs of the magnifier after first placing the magnifier on the Glass Plate (No. 21). Glass Plate, Slide, and Magnifier can then all be raised to the light for viewing. Note that the High-Power Lens must be close up to the object viewed. Both Objective (No. 41) and Mount (No. 41a) should therefore be screwed well down to secure the right focus.

## MODEL No. 20

### High Power Simple Microscope (Four-leg Type with Stage.)

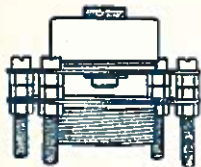

This is the same as Model No. 19 above, but mounted as shown in the picture alongside. The space between the two Ring-mounts (No. 3) accommodates the slide or object to be viewed.

## MODEL No. 21

### Medium Power Dissection Microscope (Stand Type.)

First construct Model No. 15, but arrange lenses: one in the Ring-mount and one in the Tubular-mount as

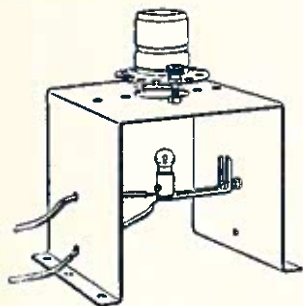

shown in the diagram Model 22. Now mount on the Instrument Stand (No. 38), by means of two 1-inch screwed rods as shown, and mount the Bi-Convex Electric Bulb in the side of the Stand as in Fitment No. 9, Position A or B, according to the degree of illumination required. A strong diffused light can be obtained for examining transparent objects by fitting an

extra Ring-mount to the under-side of the Stand as in Model No. 23 and placing a Plano-convex lens curved side

downwards in the Ring-mount from below as in Fitment No. 1, Position B, and the Frosted Disc (No. 26) into the lower Ring-mount from above. The lower Lens thus concentrates the light and the Frosted Disc prevents its being too brilliant. The slide or object to be viewed is then placed on top of the Instrument Stand between the Frosted Disc and the upper lenses.

**NOTE.**—The Optical Box (No. 1) may be used instead of the Instrument Stand if desired.

## MODEL No. 22

(As No. 21 but with Reflector.)

For this model the two upper lenses are also arranged as in the circle. See illustration of No. 21 in first column. The Reflector (No. 42) may be used in either centre or lower hole of the Instrument Stand as in

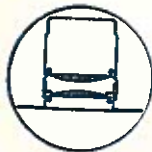

Fitment 14, Positions A and B. Try also using either the white or the polished side of the Reflector to see which gives the best results with the objects to be viewed.

## MODEL No. 23

### High Power Simple Microscope (Stand Type)

First construct Model No. 18 and mount on the Instrument Stand with two  $\frac{1}{2}$ -inch screwed bolts (No. 13), as shown. Note that the High Power Objective (No. 41) is screwed well down and that the distance between the upper Ring-Mount (No. 2) and the top of the Instrument Stand, is exactly that of two hexagonal nuts (No. 15). Terminal nuts (No. 14) are used to fasten the Upper Ring-Mount to the free ends of the bolts. The lower Ring-Mount is attached as in Fitment No. 3, Position C for the purpose of holding a Plano-convex Lens (No. 18), with its curved side towards the Reflector (No. 42). Insert this lens from below so that it occupies Position B in Fitment No. 1. The Reflector may be tried in either Position A or B of Fitment No. 14. The slide to be viewed is, of course, inserted between the upper Ring-Mount and the top of the Stand, so that the object comes directly below the High Power Lens.

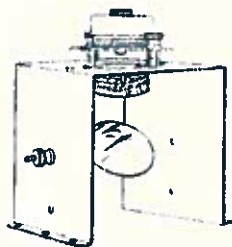

## MODEL No. 24

(Stand Type A.)

This is exactly as Model No. 23 above, but with the Frosted Disc (No. 26) dropped into the lower Ring-mount from above and the Focus Lamp (No. 24) used instead of the Reflector, as in Model No. 25, over. Note also Plano-convex lens may be put into the lower Ring-mount to act as a condenser.

## MODEL No. 25

### High Power Compound Microscope (with Lamp)

This is a very effective instrument giving a high degree of magnification to microscopic subjects, but care must be taken to adjust the focus of the lenses, the centering of the large-Pinhole Disc (No. 45), which you can see in black in the large central hole of the Instrument Stand alongside; and also the exact centering of the Lamp below it. To construct this Model, first of all make-up the Eyepiece from two Plano-convex lenses, Distance Ring and Tubular Mount and Cap exactly as Model 15. Then mount the Optical Tube (No. 4) between two Ring-Mounts as in Fitment No. 6.

Now take the High Power Objective (No. 41) and screw it for a few turns into its Mount (No. 41a) as in Fitment No. 13, Position A. You now have three assemblies, i.e., the Eyepiece, the mounted Optical Tube and the Objective. Screw the Eyepiece to the upper Ring-Mount and the Objective to the lower Ring-Mount as shown in the upper part of the diagram. The next step is to attach a third Ring-Mount to the underside of the Instrument Stand by means of two 2-inch screwed bolts (No. 46), the free ends of which project upwards, ready to take

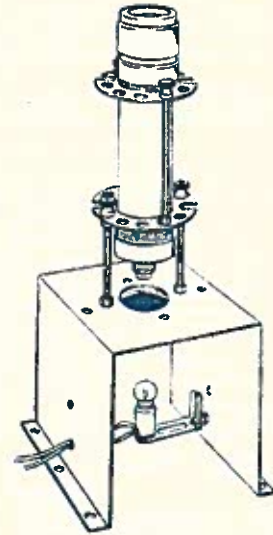

the optical unit you have just screwed together. Note the upside-down position for this third Ring-mount in the picture of Model No. 23 above. Now take a few turns with hexagonal nuts (No. 15) on to the free ends of the screwed bolts to support the optical unit, and mount as shown in the picture.

The third Ring-mount on the under-side of the stand takes the Large Pinhole Disc (No. 45) inserted from above, and a Plano-convex Lens (No. 18) from below, with the curved side of the lens towards the Lamp. Secure both the Pinhole Disc and the Lens with split-rings. Now mount the Lamp (No. 24) in its Holder (No. 5) in the lower hole of the stand as shown, and attach the free ends of the wires to the Battery.

**NOTE.**—When placing slides between the High Power Lens and the top of the Stand, be careful to see that the pin-point of light from below is illuminating the part of the slide you wish to examine. Do not be disappointed if you do not get a clear image at the first attempt. Try screwing the High Power Objective up and down making sure also that the Lamp is in a directly upright position and directly underneath the Pinhole Disc. Many High Power Microscopes costing guineas do not give better results, so that it is worth a little patience to get things exactly right.

### HIGH POWER MAGNIFIERS.

Owing to the very high magnification provided by the High Power Objective in a small field of vision, care must be taken to have the object to view properly illuminated, and at the right focal distance from the lens.

## MODEL No. 26

### o (With Reflector)

Construct exactly as Model No. 25, but use the Reflector (No. 42) instead of the Lamp. The picture shows the Reflector in the central hole at the side of the stand, but for many objects, it may be better to use it in the lower hole as in Fitment No. 14, Position B.

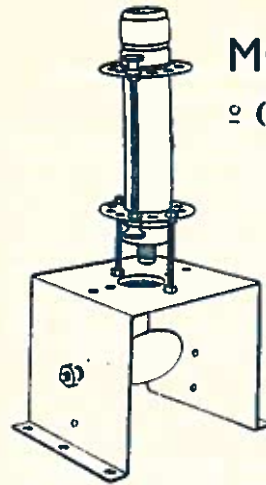

## MODEL No. 27

### Lamp Stand (Vertical Type)

This is a useful type of stand for general use in illuminating objects, slides, etc. Use the Focus Electric Bulb (No. 24) in the Lamp-holder (No. 5) and attach to a Ring-mount (No. 3) by means of a 3-inch screwed rod (No. 11) as shown in the picture. Attach free ends of lamp flex to Battery by means of the Battery Clip (No. 7).

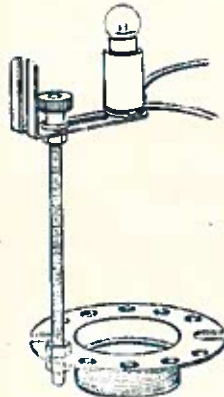

## MODEL No. 28

### (Horizontal Type)

By mounting the Lamp Holder by means of a  $\frac{1}{2}$ -inch screwed bolt (No. 13) flush with the side of a Ring-mount (No. 3), as shown in the picture, you have a type of Lamp Stand that brings the light exactly on a level with the large central hole of the Optical Box if both Stand and Box are on a level surface. This is a useful adjunct to the Shadowscope, Model No. 30.



## MODEL No. 29

### Shadowscope for Dark Room

Mount the Lamp-Holder (No. 5) with the Focus Electric Bulb (No. 24) in the central hole of the Optical Box (No. 1) and thread the free ends of the wires through the lower hole ready for attaching to the Battery. Close up the top holes at either side of the large central hole by means of  $\frac{1}{4}$ -inch screwed bolts (No. 13) and Terminal Nuts (No. 14). Replace the Optical Box Lid (No. 2), and you have a "light in a box" which will illuminate an ordinary-sized wall or ceiling, making a perfect Shadowscope.

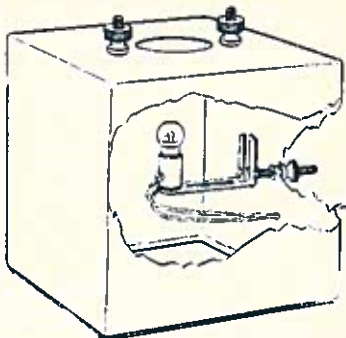

#### HOW TO USE A SHADOWSCOPE.

You can cut out figures in cardboard or sheet metal, make "animal's heads" with your fingers, show mechanical toys working in clear silhouette, leaves, insects, Japanese flowers, etc. Shadowscopes are also used technically for examining the form and accuracy of screw threads, to project geometrical figures, lines of magnetic force, etc., and for many other purposes. A little inventiveness on the part of the user will suggest numberless interesting and educative uses as well as amusement for children.

## MODEL No. 30

### Daylight Shadowscope (Horizontal Type)

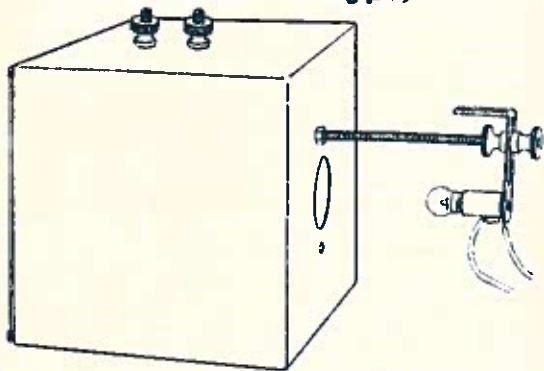

Mount the Focus Lamp (No. 24) in its Holder (No. 5) by means of a  $\frac{3}{8}$ -inch screwed rod (No. 11) as in Fitment No. 8. Attach to Optical Box (No. 1) as shown, and fill up the side holes of the Optical Box with two  $\frac{1}{4}$ -inch screwed bolts and Terminal Nuts (No. 14). The picture shows these in place at the top of the diagram. Now connect wires to Battery and instead of putting back the Optical Box Lid (No. 2), replace it with the Frosted Glass Screen (No. 22), frosted side towards the Lamp.

#### HOW TO USE.

This Shadowscope is for small objects only, which are held between the Lamp and the large central hole of the Optical Box so that the image is projected through the box on to the screen. If it is desired to have the Lamp further away from the screen, detach it and turn it into the Lamp Stand Model No. 28, which can then be placed at any suitable distance from the Optical Box. Try such objects as face, paper cuttings toy farm animals, toy soldiers, small leaves, flowers, insects or slides containing opaque objects such as feathers, etc.

## MODEL No. 31

### Shadowscope for Dark Room. (Reflection Type.)

Construct as Model No. 29, but instead of blocking up the two small holes of the Optical Box with  $\frac{1}{4}$ -inch screwed bolts place over the large central hole the Mirror Stand as in Fitment No. 10, Type 1. The light will then shine vertically upwards and be deflected horizontally on to a wall or screen, making a very interesting toy reflector-model, also providing a means of projecting horizontally live objects such as minnows, water-beetles, pond life, etc., which, in the ordinary way, could only be projected vertically.

## MODEL No. 32

### Shadowscope with Glass Stage.

Mount the Optical Box (No. 1) with the large central hole downwards to the Instrument Stand (No. 30) by means of two  $\frac{3}{8}$ -inch screwed rods (No. 11). Fitment No. 5 will help you to do this. Mount the Focus Lamp (No. 24) in its Holder (No. 5) as shown in the picture and thread the free ends of its wires through the opposite holes of the Instrument Stand ready for attaching to the Battery. Block up the small holes of the Optical Box with  $\frac{1}{4}$ -inch screwed bolts and Terminal Nuts to prevent escape of light.

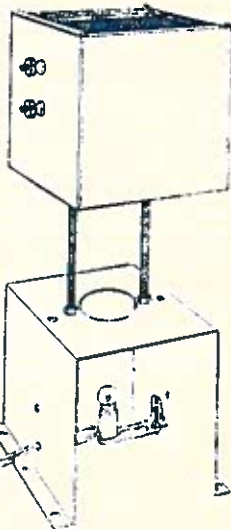

#### HOW TO USE.

Instead of replacing the Optical Box Lid (No. 2) use instead the square Glass Plate (No. 21), which the light from below will thus shine straight through. This Glass Plate will serve as a convenient "stage" on which to rest articles or objects which you wish to view in silhouette on the ceiling. Insects in a "live box" (see page 33): minnows or water-beetles in a glass dish, and various other living things of a suitable size can thus be seen greatly enlarged on the ceiling affording endless interest in the study of their movements.

## MODEL No. 33

### Daylight Shadowscope (Vertical Type).

Build this exactly as Model No. 32, but use the Frosted Glass Screen (No. 22) instead of the Glass Stage. If now you hold the objects to be projected between the Instrument Stand and the Optical Box and look down on the Frosted Screen, you will see them projected thereon as silhouette "pictures." For small objects only.

## MODEL No. 34

### Photo-Shadowgraph.

Build up exactly as in Model No. 33 above, but use the Frosted Glass Screen for focusing, prior to taking the photograph of the object you have placed in position over the light. Then, in a dark room, put your photographic plate in place of the frosted glass screen, slide the Optical Box Lid (No. 2) firmly into position to make the box light-tight, and switch on the Focus Lamp for a few seconds to make the exposure. Then switch off the lamp, remove the negative and develop and fix in the usual way. Or the Camera Cap (No. 6) may be used to screen from the light and removed for a few seconds to make the exposure.

**IMPORTANT:** Use of Cut Film or Photographic Paper. Cut film or photographic paper (3½ inches square), the latter to take the image direct without the use of a negative, may be utilized instead of glass negatives. In this case rest the Glass Plate (No. 21) on the ledges at the back of the Optical Box in order to provide a flat support for film or paper. Then replace the Optical Box Lid before taking the photograph. It is necessary to place the Frosted Glass Screen (No. 22) on top of the film or paper to keep it flat.

## MODEL No. 35

### Shadowscope for Dark Room.

#### (Downward Throw for Small Objects.)

Mount the Optical Box (No. 1) and the Instrument Stand (No. 38) exactly as in Models No. 32, 33 and 34, but instead of mounting the Lamp in the side of the Stand, mount it inside the Optical Box as in Fitment No. 7. Then close the lid of the Optical Box and you will have the light from the lamp shining downwards through the central hole of the Optical Box.

#### HOW TO USE.

Place a sheet of white paper or white card on the table underneath the Instrument Stand, and project the silhouette image downwards by placing the slide or other object on top of the Instrument Stand.

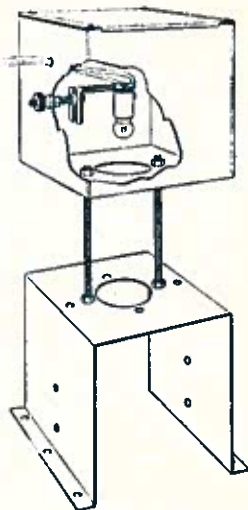

## MODEL No. 36

### Photo-Shadowgraph. (Downward Throw.)

Construct exactly as Model No. 35, but use a piece of photographic paper instead of the white paper or card. The Camera Cap (No. 6) may be used on a Ring-mount (No. 3) in the large central hole of the Optical Box, in order to make exposures.

Use in a dark-room, exposing by means of a few seconds illumination from the lamp in the Optical Box, and then developing in the usual way.

## MODEL No. 37

### Camera Obscura (Toy Model).

First attach a Ring-mount (No. 3) to the lower small hole at the side of the Optical Box by means of a ¼-inch screwed bolt and a Terminal Nut as shown in the picture. Notice that this brings the small central hole of the Box directly in the centre of the Ring-mount. Now insert the Bi-convex lens (No. 17) into the Ring-mount as in Fitment No. 1, Position B, securing with a split-ring as usual. Cut a piece of white card the size of the side-wall of the Optical Box and insert into the Box so that it is opposite the mounted lens. The picture makes this clear. Then slide on the Optical Box Lid (No. 2). If you now hold the lens towards any well-lighted object such as a tree, a building, a window, etc., and look sideways at the white paper or card through the large central hole of the Box, you will see an image projected on the white surface. Though this is a toy model it well illustrates the principle of the Camera Obscura which projects a focussed image through a small aperture in an otherwise dark room or box.

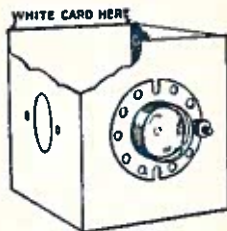

## MODEL No. 38

### Pinhole Camera (Box Type).

Affix a Ring-mount (3) flush over the large central hole of the Optical Box (2) as in Fitment No. 3, Position A. Stop up the other two small holes of the Optical Box with two ¼-inch screwed bolts and tighten with Terminal Nuts (No. 14). Now insert Small-Pinhole Disc (No. 9) in the Ring-mount and fix with Splitting (No. 10).

#### TO USE.

Place the Frosted Screen (No. 22) on the ledges at the back of the Box and then point the pinhole towards a well-lighted window. You will see the image of the window on the Frosted Screen. Mark the distance from the window at which the image is of suitable size. Now put the Camera Cap (No. 6) over the end of the Ring-mount so as to screen the pinhole, and remove the Camera to a Dark-room so that you can substitute a photographic plate for the Frosted Screen. Slide in the Lid of the Optical Box (No. 2) to make the Camera light-tight and take it back to the spot previously marked. Remove the camera cap in order to make the exposure. Note that a much longer exposure is needed with a pinhole than with a lens (a full minute or more) and that the camera must not be moved until after the cap is replaced. There is no focussing required with a pinhole, and though such a camera is only a toy, it is interesting to note that traffic or people may pass in front of it during exposure without appearing on the photograph, which will only show stationary objects, such as a building.

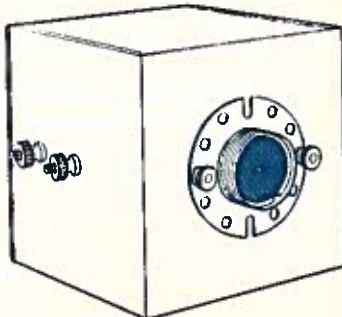

One may also observe eclipses of the sun or moon on the Frosted Screen without injuring the eyes, or try any number of experiments both with the Screen or photographically.

## MODEL No. 39

### Pinhole Camera (Midget Type).

Insert the small-pin-hole Disc (No. 9) into a Tubular-mount as in Fitment No. 2, securing with a Split-ring as usual. Next fasten together two Ring-mounts (No. 3) back to back and screw on the Tubular-mount containing the pin-hole. The picture for Model No. 43 will also help you to see how this is done. On the other Ring-mount screw on a Tubular-mount containing the Frosted Disc (No. 26) for focussing the image. Or the Frosted Disc may be inserted in the Ring-mount itself as in Model 43. (See Note on page 35, concerning Midget Type and

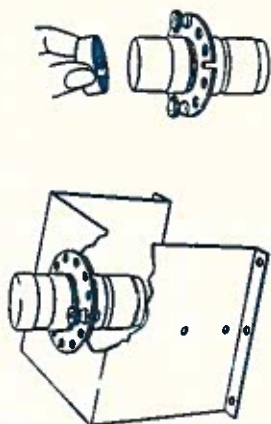

Button-Hole-Picture Cameras and their use.) To give stability and to prevent movement during exposure Midget Type and Button-Hole-Picture Cameras may be mounted on the Instrument Stand (No. 38) as shown here, the Ring-mounts being first affixed, back to back, to the Stand.

## MODEL No. 40

### Pinhole Camera for Transparent Objects.

Mount the Pinhole Camera Model No. 38 to the Instrument Stand (No. 38), by means of two 3-inch screwed rods, exactly as in Model No. 32, but having the Focus Lamp (No. 24) mounted through the lower small hole at the side of the stand instead of the central one. Small opaque objects, transparencies or slides, may then be seen on the Frosted Glass Screen (No. 22) placed on top of this model, and afterwards photographed by means of the electric light below them. (See *Photographic Notes on pages 34 and 35.*)



## MODEL No. 41

### Lens Camera (Box Type).

Build up as Pinhole Camera Model No. 39, but use the Bi-convex Lens (No. 17) instead of the pinhole disc. If you look at Fitment No. 1, Positions B and A, you will see that this gives you two "forward" positions for the lens, B being further away from the back of the Box where the negative will be placed, and A being a fraction nearer, due to the lens being on the inside of the Ring-mount. To get two "back" positions, place the Bi-convex Lens in another Ring-mount mounted inside the Box, as in Fitment No. 1, Position A. To get the fourth position, nearest of all to the back of the box, place in the inside Ring-mount as in Fitment No. 1, Position B. The lower of the two pictures shows how the second Ring-mount is fixed behind the front one, which can be used to hold the Camera Cap (No. 6).

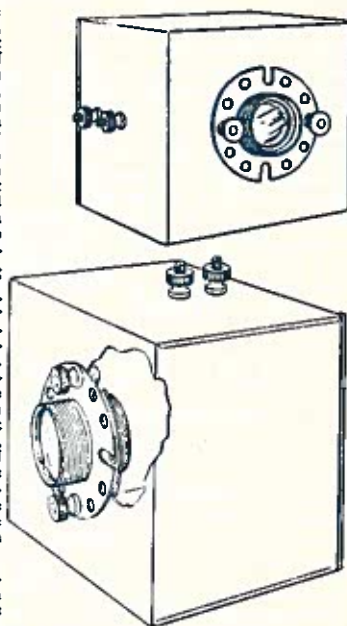

These alternative positions of the lens are necessary because this Box-Type Camera has no sliding focus. The final focus is obtained by moving the camera nearer to or further away from the object it is desired to photograph until the sharpest image is seen on the Frosted Glass Screen (No. 22). In most cases, especially when the light is very bright, a sharper photograph may be obtained by first inserting the Lens-stop (No. 44) before the lens, and securing as usual with a Split-ring (No. 10)

#### HOW TO USE.

For a "close-up" photo, fix the lens furthest forward and try about 15 inches from the subject. For a smaller picture fix the lens in the next position and try about 21 inches from the subject. For, say, a  $\frac{1}{2}$  full-length portrait, place the lens one stage nearer to the negative, i.e., in the front of the rearmost Ring-mount and try about four feet from the subject. For infinity (20 feet or more) fix the lens in the fourth position, i.e., in the back of the rearmost Ring-mount. \*See also Photo Hints, page 34.

## MODEL No. 42

### Lens Camera (Box Type with Hood).

Construct exactly as Model No. 41, but screw a Tubular Mount (No. 39) on to the forward Ring-mount to take the Camera Cap (No. 6). The Tubular Mount helps to prevent the intrusion of side-light, and in conjunction with the Lens Stop, will help to give a sharper photo.

## MODEL No. 43

### Button-Hole-Picture Camera.

First place a Lens-stop (No. 44) into a Tubular Mount Cap (No. 40). Then insert a Plano-convex lens with the curved side inwards and secure with a split ring. Put the Cap on to the Tubular Mount (No. 39) and screw to the Ring-mount as shown. Mount to the Instrument Stand as in Model No. 39 and use the back Ring-mount (No. 3) to contain the Frosted Disc upon which you can focus the image. A second Tubular Mount and Cap must then be affixed to the back Ring-mount as shown in Model 39.

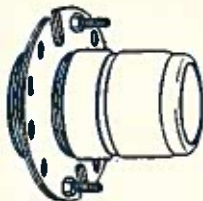

## MODEL No. 44

### Button-Hole-Picture Camera. (2-Lens Type.)

Built up as Model above, but this time there is another Plano-convex lens in the Ring-mount, as indicated in the diagram.

Note.—See page 35 for Hints on the Use of Midget and Button-Hole Picture Cameras.

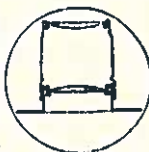

## MODEL No. 45

### Micro-Reducing Camera.

Attach Ring-mounts, above and below, to the Instrument Stand as shown and screw on to the top one the High Power Objective (No. 41) inserted into its Mount (No. 41a) as show in Fitment No. 13, Position B. The Objective should be screwed well down. Now insert the Frosted Disc (No. 26) into the lower Ring-mount as in Fitment No. 1 Position B, and secure by means of a split-ring. Then screw on to the lower Ring-mount a Tubular Mount with its cap, and the camera is ready for focussing. This is a highly interesting and novel kind of camera, since it reduces portraits, objects, etc., to a very tiny size so that the photos have to be viewed through a magnifier. A large collection of these tiny photos can thus be contained on one page of an album.

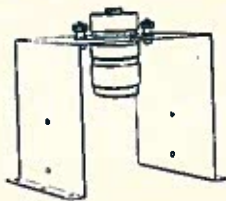

(See Photographic Notes on pages 34 and 35.)

## MODEL No. 46

### Micro-Reducing Camera (For Photo Negatives).

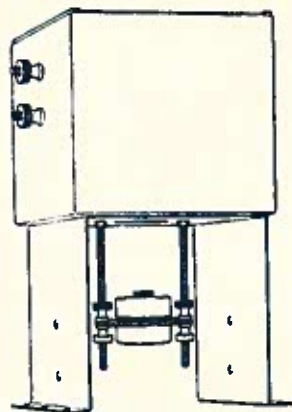

This is another new and ingenious form of camera for making tiny photo-prints (about an eighth of an inch in diameter) from negatives. The negative is to be placed on the ledges at the top of the Optical Box under the slide lid and then exposed directly under an electric light. The construction of this model can be clearly seen from the picture. The High Power Objective is screwed to the upper of the two Ring-mounts just as in Model

No. 45, and the lower Ring-mount contains the Frosted Disc (No. 26) and accommodates the Camera Cap (No. 6). The distance of the High Power Objective from the Optical Box must be as in the picture, regulated by the number of turns of the nuts on the 3-inch screwed bolts which are used for mounting.

See note on page 35 concerning Midget Type and Button-Hole-Picture Cameras and their use.

## MODEL No. 47

### Photo Copier and Enlarger.

This Model is best constructed in two sections. First attach a Ring-mount (No. 3) to the Optical Box as in Fitment No. 3, Position A, but use 1-inch screwed bolts (No. 12) instead of the  $\frac{1}{2}$ -inch bolts, leaving the free ends projecting. Screw on two extra hexagonal nuts for about two-thirds of the way down the screwed bolts as shown. Take a Tubular Mount (No. 39) and insert first a Lens stop (No. 44) and then a Plano-convex lens (No. 18) as in Fitment No. 2. The curved side of the lens must be uppermost. Secure with a Split-ring (No. 10) and then screw the Tubular Mount on to the Ring-mount. Stop up the two side holes of the Optical Box with two  $\frac{1}{4}$ -inch screwed bolts (No. 13) and Terminal Nuts. The upper part of the picture shows this assembly ready for mounting.

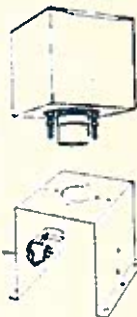



For the lower part, mount the Focus Lamp (No. 24) flush with the side of the Instrument Stand as shown, and in Fitment No. 12.

This is for the purpose of illuminating the object to be photographed. Now insert the free ends of the screwed bolts into the corresponding holes of the Instrument Stand and secure from below the Stand by means of two Terminal Nuts (No. 14). You will thus see that the Tubular Mount projects downwards through the large centre hole of the Instrument Stand, ready to take the Camera Cap (No. 6).

#### TO USE.

Place the Copier on a flat surface. Place the object to be photographed immediately under the lens; attach the bare ends of the lamp wires of the Battery to give the necessary illumination. Remove the slide Lid of the Optical Box and put the Frosted Glass Screen (No. 22) in its place, frosted side downwards. You will then see a clear image of the object below. Focus by means of screwing the Tubular Mount up and down until the image is at its clearest, and then photograph in the usual way. Pictures from books, coins, medals, signatures, fingerprints, postage stamps, flowers, grasses, ladies' watches, butterflies and all manner of flat or flattish objects can be photographed by means of this model.

## MODEL No. 48

### Electric Lamp Photo-Printer.

Construct exactly as Model No. 30, but place a Ring-mount (No. 3) over the large central hole of the Optical Box (No. 1) in order to hold the Camera Cap (No. 6). The two small side holes of the Optical Box should be stopped up with  $\frac{1}{2}$ -inch screwed bolts in order to make the Box light-tight.

#### TO USE.

In a dark room rest the negative on the ledges at the back of the Box, place the printing-out photo paper face downwards against it and then the Glass Plate (No. 21) to keep the photo paper in position. Then replace the Optical Box Lid (No. 2). To expose, attach the lamp-wires to the Battery and remove the Camera Cap for a few seconds according to the density of the negative. Develop and fix as usual.

## USE OF SPLIT-RINGS

Whenever you fix a Lens, Lens-Stop, Frosted Disc, Coloured Disc or Pinhole-Disc, always remember to secure by means of a Split-ring (No. 10), wedged evenly down so that the object inserted is kept flat.

## MODEL No. 49

### Electric Lamp Photo-Printer. (Improved Type.)

Attach the Camera Box (No. 1) as shown, to the Instrument Stand (No. 38) by means of the same  $\frac{1}{2}$ -inch screwed bolts used to fix the Ring-mount (No. 3), which you see in the picture immediately above the lamp bulb, as a support for the Camera Cap (No. 6). Then mount the Focus Lamp (No. 24), as shown or in the lower hole. Use as Model No. 48.

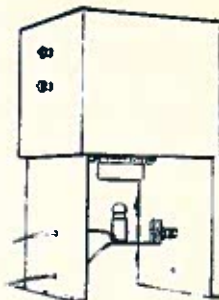

## MODEL No. 50

### Red Lamp for Dark Room.

Construct exactly as Model No. 2, but instead of a lens in the Ring-mount, use the Red Transparent Disc (No. 27). Two or more of these discs increases the safety of the light.

## MODEL No. 51

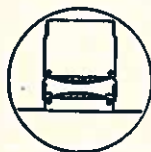

### Magic Lantern

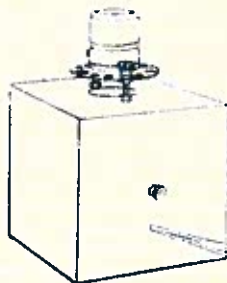

Place a Ring-mount (No. 3) inside the Optical Box (No. 1) as in Fitment No. 3, Position C, but using 1-inch screwed bolts (No. 12) so that the free ends project outwards ready for taking the upper mounting. Insert into the Ring-mount a Plano-convex lens (No. 18) in Position B of Fitment No. 1—with the curved side of the lens towards the inside of the box. This acts as a condenser. Now mount the Bi-Convex Lamp (No. 25) in its Lamp-holder in the central hole at the side of the Optical Box as in Fitment No. 7 so that the lamp is directly underneath and exactly central to the lens. Thread the free ends of the wires through the remaining hole ready for attaching to the battery. Now fix a Ring-mount to the free ends of the projecting screwed bolts at the distance shown and insert into it a Plano-convex lens (curved side upwards) as Fitment No. 1, Position B. Place a third Plano-convex

lens curved side downwards in a Tubular-mount (No. 39) as in Fitment No. 2. The circle shows the lens positions. Place the Cap (No. 40) over the Tubular Mount and screw on to the upper Ring-mount as shown in the picture.

#### TO USE.

Attach lamp wires to the Battery by means of the Battery-clips (No. 7) and project the light on to a wall or screen in a dark room. See that the patch of light is properly circular. If it is not this means that the lamp is not properly central. Toy strip magic-lantern slides, microscopic slides, toy films, and many other suitable subjects may be projected by this model by holding them between the upper Ring-mount and the large central hole of the Optical Box. To secure the sharpest possible image, focus by screwing the Tubular-mount up or down. An endless amount of entertainment and experiment is provided by this model.

## MODEL No. 52

### Daylight Magic Lantern (Type A).

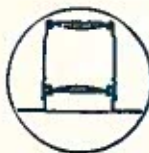

Fix a Ring-mount (No. 3) to the Optical Box as in Fitment No. 3, Position A, but use 3-inch screwed rods (No. 11) instead of the 1/2-inch screwed bolts, leaving the free ends

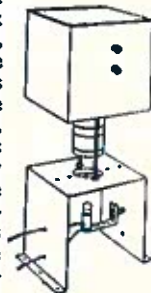

of the rods projecting outwards ready for mounting the Optical Box to the Instrument Stand. Place one Plano-convex lens into the Ring-mount as in Fitment No. 1, Position A, with the curved side upwards, and another Plano-convex lens into the Tubular Mount Cap (No. 40) with the curved side upwards. (Lens positions are shown in circle). Secure the lenses by means of Split-rings (No. 10), push the cap on to the Mount and screw on to the Ring-mount. For the lower part of this model fix a Ring-mount to the under side of the large central hole of the Instrument Stand (No. 38) as in Fitment No. 3, Position C and insert into it from below another Plano-convex lens with the curved side upwards, i.e., the flat side towards the lamp. Mount the Bi-Convex Lamp (No. 25) as shown, and as described in Fitment No. 7 and then fix the Instrument Stand to the Optical Box by means of the free ends of the screwed bolts, securing firmly with nuts, as the picture clearly shows. Focus by sliding the Tubular-Mount Cap up or down. To obtain a rather larger magnification when viewing small objects, mount the Optical Box a little closer to the Instrument Stand and use the lens positions as in Model No. 51.

#### TO USE.

Use the same kinds of subjects as for the Magic Lantern, placing the slides, etc., on top of the Instrument Stand

and projecting the image upwards so that it appears on the Frosted Glass Screen (No. 22) which you will place on the ledges of the Optical Box instead of the slide Lid. Focus until the image is sharpest, by screwing the Tubular mount up or down. Many interesting experiments can also be carried out with this "Daylight" type which, of course, gives even better results in a dark room.

## MODEL No. 53

### Daylight Magic Lantern (Type B).

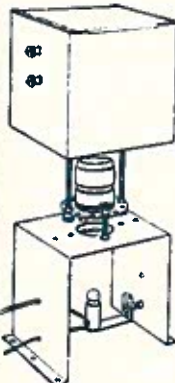

Construct lower half of this as Model No. 52 including the Plano-Convex lens inserted in the under side of the Ring-mount ; but before mounting the Optical Box (No. 1) on the free ends of the 3-inch rods, fix the Ring-mount and the Tubular-mount in the position shown in the drawing, i.e., midway between the Instrument Stand and the Optical Box instead of being attached to the Optical Box itself. The arrangement of lenses is as follows : one Plano-convex lens (No. 18) inserted into the Ring-mount as in Fitment No. 1, Position B, with the curved side upwards, and one Plano-convex

lens in the Tubular Mount Cap as in Fitment 2, also with the curved side upwards. You will thus find, when you have put the Cap on the Tubular-mount and screwed the latter on to the Ring-mount, that the curved sides of the lenses face each other (see small circle). Use as Model No. 52, and compare the relative performances of the two alternative lens systems.

## MODEL No. 54

### Low Power Projection Microscope.

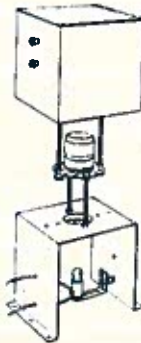

This is a particularly effective Model, yet simple to construct. In spite of its imposing appearance. The central Ring-mount (No. 3) is fixed to the Optical Stand (No. 38) by means of two 2-inch screwed bolts (No. 46) and the necessary nuts. The Optical Box (No. 1) is fixed from above to the Ring-mount by two 3-inch screwed rods (No. 11). Fitment No. 5 will help you if in doubt. Only one lens is needed (a Plano-convex lens, No. 18), and this is rested on the Distance Ring (No. 8) inserted into the Tubular-mount (No. 39) as Fitment No. 2. Lens is curved side downwards.

Fix a Ring-mount to the under side of the Instrument Stand to contain a Plano-convex Condenser lens and frosted disc as in the previous model.

#### TO USE.

Place the object to be viewed, slides, transparencies, toy films, etc., on top of the Instrument Stand; light the lamp, and focus on to the Frosted Glass Screen (No. 22) which you place on top of the Optical Box.

## MODEL No. 55

### Medium Power Projection Microscope.

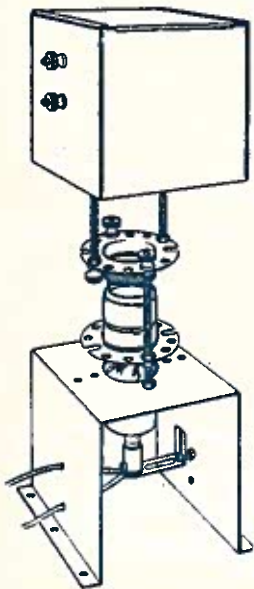

By referring to the previous Model 54, you will be able to construct this Instrument with ease. Note however, that the 3-inch screwed rods (No. 11) are used on the Instrument Stand below, and the central Ring-mount (No. 3) is secured to the Optical Box (No. 1) by two 2-inch screwed bolts (No. 46) instead of vice-versa. Two Plano-convex lenses are inserted, one in the Tubular Mount (No. 39) and one in the Cap (No. 40) as in the Ramsden Eyepiece, Fitment No. 2a. (See small circle for lens positions.) Owing

to the very small space between the two Ring-mounts, the Tubular-mount and Cap are best screwed to the lower Ring-mount before fixing the Optical Box with its attached Ring-mount, to the free ends of the 3-inch screwed-rods, which project upwards from the Instrument Stand. Fix a Condenser Lens to the underside of the Instrument Stand as described in the next model (Model No. 56). To secure greater magnification, alter the position of the lenses so that one rests on the Distance Ring (No. 8) in the Tubular-mount as in Model No. 54, and the other is inserted into the Ring-mount below it as in Fitment No. 1, Position B.

#### TO USE.

Place the microscopic slide, or other object to be viewed, between the Instrument Stand and the lower Ring-mount, light the lamp, and focus on to the Frosted Glass Screen

(No. 22) which you can rest on the ledges at the top of the Optical Box. Insects' legs, all kinds of small objects mounted between the Glass-slides (No. 23), and many other small objects are then seen enlarged in a circle of light on the Frosted Screen which should, of course, be placed frosted side downwards.

## MODEL No. 56

### High Power Projection Microscope.

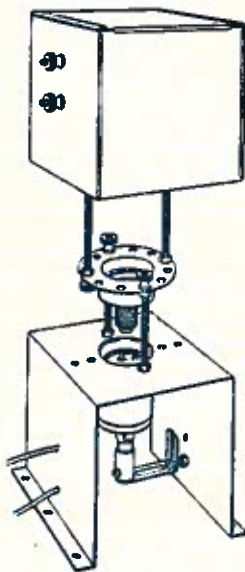

Your experience of the two previous Models (55 and 56) will enable you to construct this one with ease. Note that the central Ring-mount (No. 3), between the Optical Box and the Instrument Stand, is fixed from below by two 2-inch screwed bolts (No. 46) and the Optical Box at the top is attached to the central Ring-mount by two 3-inch screwed rods (No. 11) with about one inch of their free ends projecting *inside* the Optical Box. This arrangement brings the central Ring-mount exactly midway between Box and Stand. Now screw the High Power Objective (No. 41) for a few turns only into its Mount (No. 41a), as in Fitment No. 13, Position A, so that the lens points downwards.

With regard to the Instrument Stand, the Bi-convex Lamp (No. 25) is mounted in the lower hole, and the wires are threaded through the two side holes opposite, while the lower Ring-mount fixed to the *under* side of the Instrument Stand as in Fitment No. 3, Position C (held in place by the heads of the two 2-inch screwed bolts which support the central Ring-mount), contains a Plano-convex lens (No. 18) inserted from below, with the curved side downwards to act as a condenser. A Tubular-mount (No. 29) screwed on to this Ring-mount, and which you can see in the picture immediately over the lamp, completes the assembly.

#### TO USE.

This Instrument projects microscopic objects, mites, and other very minute objects in a greatly enlarged image on the Frosted Glass Screen (No. 22). Focus until the image is at its sharpest and clearest by screwing the High Power Objective up or down in its mount.

## MODEL No. 57

### High Power Projection Microscope. (Dark Room Type.)

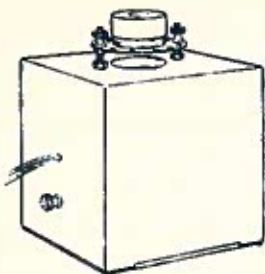

Fix the High Power Objective and Mount (No. 41 and 41a) to the Optical Box (No. 1) exactly as on the instrument Stand in Model

No. 23, noting that the second Ring-mount is fixed to the under side of the Optical Box in the same way as under the Stand. This lower Ring-mount is to accommodate a 2-lens Condenser as shown in the small circle, made by inserting a Plano-convex lens (No. 18) into a Tubular-mount (No. 39) as in Fitment No. 2, with the curved side upwards; then a Distance Ring (No. 8); then another Plano-convex lens—securing by a Split-ring (No. 10). Note that the lenses are practically touching, with their curved sides together. This Condenser, when screwed to the Ring-mount in the Box, comes just over the Lamp (use the Bi-convex Bulb, No. 25), which you will mount in the lower hole of the Optical Box (see Fitment 7), threading the free ends of the wires through the central hole ready for attaching to the Battery.

#### TO USE.

This is for minute microscopic objects only, such as mites, mosquitos, botanical sections, etc. Hold the slide between the High Power lens and the top of the Optical Box or secure by means of the spring-clips (No. 43) as in Fitment 15, and project on to a white screen or sheet of white card in a dark room. Be sure to see that the lamp is exactly central to the Condenser above it, and focus by screwing the High Power Objective up or down until the image is at its clearest in the largest possible circle of light. From two to four feet away from the screen normally gives the best results.

## MODEL No. 58

### Low Power Photo-Microscope.

Construct exactly as Model No. 54, but use as a photographic instrument by using glass negative, cut film or photo-paper after focussing on the Frosted Glass Screen. Then develop and fix as usual.

NOTE.—In this and the next two models (Nos. 59 and 60), you may use the Camera Cap (No. 6) after fixing a Ring-mount (No. 3) to the under side of the Optical Box to accommodate it.

## MODEL No. 59

### Medium Power Photo-Microscope.

Construct exactly as Model No. 55, but use for photographic purposes.

## MODEL No. 60

### High Power Photo-Microscope.

Construct exactly as Model No. 56, but use for photographic purposes.

## MODEL No. 61

### Hand

### Kaleidoscope.

Take the three Strip Mirrors (No. 19) and fix them in a triangle, so that they reflect inwards, by means of the two Rubber Bands (No. 37) as shown in picture A. Now insert into the Optical Tube (No. 4) as shown in picture B. Then mount on two Ring-mounts as shown in picture C and in Fitment No. 6. (See Page 33.)

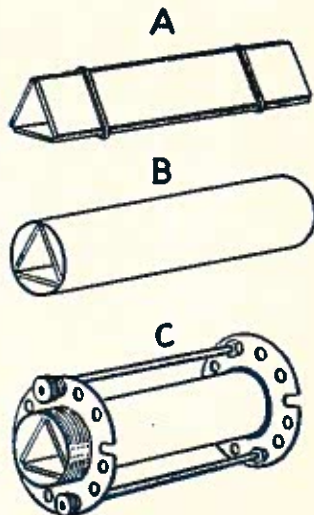

## MODEL No. 62

### Simple Magnifying Kaleidoscope.

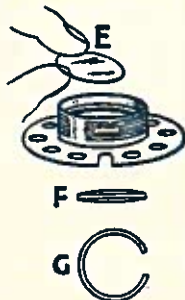

Insert the Bi-convex Lens F (No. 17) at one end of Model No. 61, as shown in picture E, fix with a Split-ring G (No. 10), and view through the end in which you have just inserted the Lens. (See Page 33 for Hints on the Use of the Kaleidoscope.)

## MODEL No. 63

### Illuminated Kaleidoscope (Box-type with Lamp)

Take the Simple Magnifying Kaleidoscope you have assembled as Model No. 62 and fix to the Optical Box (No. 1) with 1-inch screwed bolts, the heads of which are also to secure a second Ring-mount, fixed from inside the Box, as in Fitment No. 3, Position C. This Ring-mount is to contain a Plano-convex lens (No. 18) inserted from inside the Optical Box, with the curve pointing downwards towards the Lamp. This lamp is mounted in the lower hole and the wires threaded through the centre hole at the side of the Box ready to attach to the Battery. The picture of the Stand-mounting in Model No. 64 below shows the identical positions of Ring-mounts, screwed bolts, etc., except that the lamp in the box (Bi-convex Bulb, No. 25), replaces the Reflector and that a Frosted Disc (No. 26) is inserted into the lower Ring-mount from inside the Box, as in Fitment No. 1, Position B.

See Kaleidoscope Notes, Page 33.

## MODEL No. 64

### Illuminated Kaleidoscope

#### (Stand Type A.)

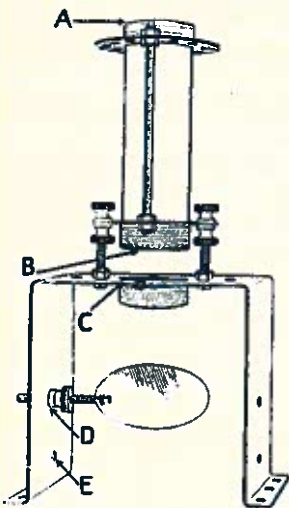

This Model is self-explanatory, if you refer to the diagram, and to the previous models you have constructed. Points A and B are Lens positions, Point C is where the objects to be viewed are placed; points D and E show alternative positions for the Reflector or the Lamp-holder.

(See also page 33, Hints on the Use of the Kaleidoscope.)

## STOP PRESS.

See next column for important announcement re Photographic Materials.

## MODEL No. 65

### Illuminated Kaleidoscope. (Stand Type B.)

This is constructed as Model No. 64, but use a Focus Lamp Bulb (No. 24) instead of the Reflector, and use a Frosted Disc (No. 26) in the lower Ring-mount to diffuse the light.

See Kaleidoscope Notes, Page 33.

Mount the Simple Magnifying Kaleidoscope you have just constructed (Model No. 62) on to the Instrument Stand by means of two 1-inch screwed bolts (No. 12) and nuts, as shown in the picture of Model No. 64, fixing a lower Ring-mount from underneath the Instrument Stand to hold the Frosted Disc (No. 26), in order to diffuse the light, as, in this Model, the Focus Lamp Bulb (No. 24) is used instead of the Reflector shown in Model 64. Try mounting it either in Hole D, or Hole E, according to the kind of object you are viewing.

See Kaleidoscope Notes, Page 33.

## MODEL No. 66

### Reflection Kaleidoscope. (Type A.)

Construct exactly as Model No. 63, but fit two 1-inch screwed bolts and one ½-inch screwed bolt to the top Ring-mount to form a Mirror Holder. Fitment No. 10 will help you to do this, as also will the picture of Model No. 67 below.

#### TO USE.

Adjust the Mirror as in Fitment No. 10, and look closely into it horizontally. You will then see a reflected image as though you were peering straight into a horizontal Optical Tube.

At the time of going to press we are able to make the important announcement that standard - grade Photographic Materials, Plates, Cut-Film and Paper, made specially for Construments, will be available almost immediately. With these materials will be supplied information regarding suitable times of exposure for most of the photographic Construments Models. Be sure to ask your nearest Construments Dealer for supplies.

## MODEL No. 67

### Reflection Kaleidoscope.

#### (Type B.)

Construct as Model No. 66 (see picture alongside), but place the Bi-convex lens (No. 17) in the upper Ring-mount to act as an eye-piece, and the Plano-convex lens in the lower Ring-mount at the bottom of the Optical Tube with its curved side downwards.

#### TO USE.

Hold a sheet of white paper about 15 inches to 18 inches from the mirror, and you will see the illuminated Kaleidoscopic images projected on to it. By turning the Optical Tube round and round in its mounts, and by moving the slides or other subjects to and fro you can create an ever-changing display of patterns and designs.

See *Kaleidoscope Notes*, Page 33.

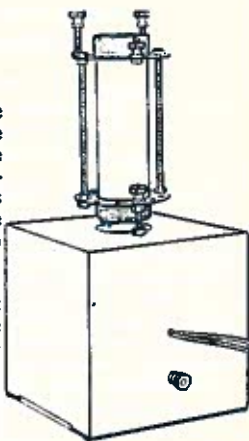

## MODEL No. 68

### Reflection Kaleidoscope (Type C.)

This type of Reflection Kaleidoscope illustrates in a most interesting manner the difference in focal length between the Plano-convex and the Bi-convex lens in the eye-piece. By substituting a Plano-convex lens (No. 18) for the Bi-convex used in Model No. 67 in the upper Ring-mount, you will see that although this model is identical with No. 67 in all other ways, you will only be able to reflect an image to a distance of about 4 inches from the mirror. Use otherwise as Model No. 67.

See *Kaleidoscope Notes*, Page 33.

## MODEL No. 69

### Hand Micro-Kaleidoscope

Construct exactly as Model No. 62, but insert a Plano-convex lens (No. 18) in the Ring-mount not already occupied by the Bi-convex lens. This will give most interesting enlarged views of the subjects chosen, capable of infinite variation.

#### TO USE.

Hold very close to the objects to be viewed (about 1 inch), taking care to have them in a good light. If you wish to see the Kaleidoscopic patterns created by transparent or semi-transparent objects, hold them up to the light and look through them. Try the effect of using either end of the Kaleidoscope as the eye-piece

## MODEL No. 70

### Micro-Kaleidoscope (Stand Model)

Construct exactly as Model No. 69, but mount on the Instrument Stand as in Model No. 64, by means of two 1-inch screwed bolts (No. 12) and use either the white or the polished side of the Reflector to give the necessary illumination to the subject.

## MODEL No. 71

### High Power Micro-Kaleidoscope

Construct as Model No. 64, but screw the High Power Objective (No. 41) and its Mount (No. 41a) to the lower Ring-mount before fixing to the Stand. The position of the High Power Objective is as Model No. 25, i.e., with the lens part pointing downwards. For this model you will need to mount the Kaleidoscope on to the Stand by means of 2-inch screwed bolts (No. 46) instead of the 1-inch screwed bolts, owing to the extra space required above the Stand.

## MODEL No. 72

### Tele-Kaleidoscope

Construct as shown, but with one Plano-convex lens only in the Tubular-mount, inserted as Fitment No. 2. View through the Bi-convex lens end of the Kaleidoscope and you will get a "telescopic" effect instead of the diminishing one of Model No. 73 overleaf.

## MODEL No. 73

### Reversed Tele-Kaleidoscope

Construct the Kaleidoscope exactly as Model No. 62, but make a Condenser from two Plano-convex lenses separated by the Distance ring in the Tubular-mount as shown in the small circle illustrating lens positions Model No. 57. Place the Tubular-mount Cap over the Condenser and screw on to the Ring-mount not already occupied by a lens. View through the single lens end and you will be able to see Kaleidoscopic patterns thrown to a distance as though through the reverse end of a telescope.

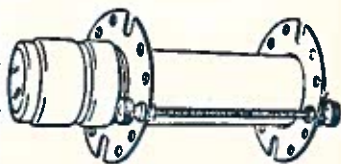

#### TO USE.

Bright objects at the end of a room, flowers, lights, opposite windows, furniture—a hundred things suggest themselves.

(See also *Kaleidoscope Notes*, page 33.)

## MODEL No. 74

### Projection Kaleidoscope

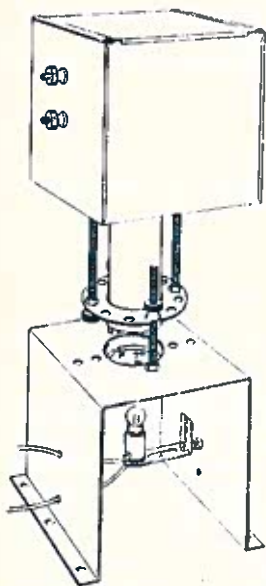

This Model is a particularly interesting and novel. It can be used either in daylight or in a dark room for projecting Kaleidoscopic images, patterns, etc., on to the Frosted Glass Screen (No. 22) which rests on the ledges at the top of the Optical Box. Though this looks a very imposing instrument, it is quite easily built-up by observing the picture alongside. First build up the Hand Kaleidoscope as in Model No. 61, but before securing the 3-inch rods used for the mounting to the upper Ring-mount, insert their free ends through the holes either side of the large central opening in the Optical Box (No. 1), and secure them *inside* the Box by hexagonal or terminal nuts. This assembly is then mounted to

the Instrument Stand (No. 38) with two 2-inch screwed bolts, at a distance from the Stand as indicated in the picture. Note that the lower Ring-mount is fixed nearly half-way down the upward projecting screwed bolts. The Instrument Stand is also provided with a Ring-mount on its under side, as in Model No. 64. This is to contain a Frosted Disc (No. 26) for the purpose of diffusing the light from the Focus Bulb (No. 24) mounted in the central hole of the Stand.

A Plano-convex lens (No. 18) is inserted into the upper Ring-mount from inside the Optical Box (curved side upwards) in order to focus the image on to the Frosted Glass Screen which you will now rest on the ledges at the top of the Optical Box.

#### TO USE.

Transparencies, coloured threads, small opaques, illuminated from above cellophane or celluloid scraps or almost any oddments can be placed on the Stand (see Position C in the picture of Model No. 64), and can be seen projected on the Frosted Glass Screen.

See *Kaleidoscope Notes*, page 33.

## MODEL No. 75

### Photo-Kaleidoscope.

Build exactly as Model No. 74, but use for photographing the Kaleidoscopic images by replacing the Frosted Glass

Screen by a photo plate, piece of cut film or square of photographic paper. In this model the lower Ring-mount (see Position B in picture of Model No. 64), can accommodate the Camera Cap (No. 6).

## MODEL No. 76

### Watch Projector (Reflection Type).

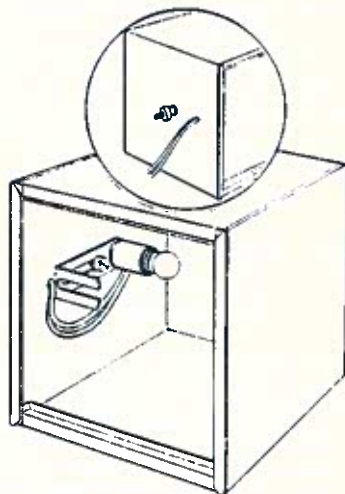

Affix the Bi-convex Electric Bulb (No. 25), in its Holder (No. 5) to the central one of the two small holes in the side of the Optical Box (No. 1), as shown in the sketch, threading the free ends of the wires through the remaining hole ready for attaching to the Battery. Construct a Mirror-holder (see Fittment No. 10), and mount to the large central hole of the Optical Box by means of two 1-inch screwed-bolts, so that the Ring-mount supporting the Mirror is about half-an-inch from the top of the Optical Box. Then insert in the Ring-mount from above the Bi-convex Lens (No. 17) and secure with a Split-ring. If you now place a watch on the table, or any other flat surface, and put the Optical Box, minus its lid (No. 2), over the watch, you will be able to see the illuminated watch-face in the Mirror. To project an illuminated image horizontally, on to a wall or screen 2 or 3 feet away, simply move the Instrument, with the watch underneath it, to a suitable distance until the image of the watch dial on the wall is at its clearest. It may be necessary to slew the lamp sideways or otherwise ensure that the watch is illuminated from the most effective angle, but the correct position can be determined by practical trial in a dark room.

**NOTE.**—It is important that the room in which this projection is attempted should be absolutely dark, as

any stray light or even a faintly-outlined window at night, will make the image only a very faint one.

## MODEL No. 77

### Watch Projector (Photo Type).

Build up exactly as Model No. 47, but use it for projecting on to the Frosted Glass Screen (No. 24) at the top of the Optical Box, or for photographing the image by substituting a glass photo plate or piece of cut film for the Frosted Screen. The watch should not be too thick—a lady's watch or a flat wrist-watch taken from its straps are best for the purpose, as anything thicker would be out of focus by reason of being too near to the lens.

## MODEL No. 78

### Epidiascope.

Construct exactly as Model No. 76, but use for projecting small, flat objects such as coins, stamps, small pictures, crests, flowers which should be placed, if possible, on a contrasting background in order to throw up the image with the greatest clearness. In this Model the lamp should be placed as near as possible to the object to be projected so long as it does not cast any interfering beams of light into the lens. The experimenter will doubtless be able to construct for himself many other forms of Epidiascope, such as models which project the image vertically on to a ceiling instead of being reflected horizontally by a mirror. In this class of Instrument there is abundant scope for ingenuity and entertainment.

## MODEL No. 79

### Reflectoscope.

Build up as Model No. 8, but attach to the Ring-mount containing the lens, mirror supports as in Fitment No. 10 to contain a Square Mirror (No. 20). This Model illustrates on a toy scale the principles of the Reflectoscope, and may be used for viewing ordinary objects such as small pictures, lantern slides, films, postage stamps and a great variety of objects, which should be placed on top of the Optical Box centrally under the lens. Look into the mirror horizontally instead of downwards into the lens and see the objects reflected horizontally in a very pleasing manner.

## MODEL No. 80

### Model of a Periscope.

This is only a toy model, but it affords amusement and interest in enabling you to see over, for instance, a pile of books, a screen, a window sill or other obstruction, and illustrates the principles of the Periscope. Simply place the Optical Box (No. 1) to the Instrument Stand (No. 38). Now construct two Mirror-holders as in Fitment No. 10, and place one in the large central hole of the Optical Box with the glass side of the mirror away from you, and the other underneath the Instrument Stand with the glass side towards you. By adjusting the position of these Mirror-stands and looking into the lower one you will see a reflection of what the upper mirror "sees" over the barrier. The upper mirror may also be turned round so that it sweeps different objects successively into view.

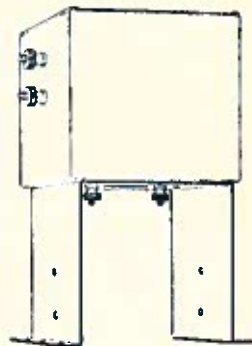

## MODEL No. 81

### Astronomical Telescope.

This model of an Astronomical Telescope is very simple to construct. First mount the Optical Tube between two Ring-mounts as in Fitment No. 6. Then make a Ramsden Eyepiece as in Fitment No. 2a. Screw the Ramsden Eyepiece to the Ring-mount at one end of the assembly, and place a Bi-convex lens (No. 17) in the other Ring-mount, securing with a Split-ring (No. 10). View through the Ramsden Eyepiece. The image is, of course, upside-down or inverted, and the entire model is a miniature of a modern refracting astronomical telescope. Use this model to view the moon, distant Church Towers, landscapes, etc. Startling results cannot be expected from this model, since the Optical Tube is short, and the focal length of the lenses is equally so, but the principles of telescopes are well illustrated and most instructive.

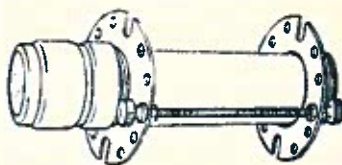



## How to Mount, Use and Select Objects for Microscopes, Kaleidoscopes and Micro-Photography

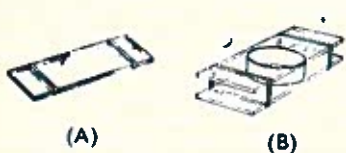

(A)

(B)

1. Crystals of sugar, salt, fibres of cotton, wool, silk, etc., cheese dust, pollen, tiny parts of flowers or insects, and many other minute objects may be placed on the centre of one of the Glass Slides (No. 23) with a needle or knife-blade, ready for viewing through the various Instruments.

2. Flat objects or objects capable of being flattened may be sandwiched between two of the glass slides referred to above, and held together by two Rubber Bands (No. 37) (see Picture A). Objects such as the following may be used: legs and wings of insects, small clippings of coloured cellophane (for the Kaleidoscope), pieces of fabric, silk, etc., grasses, scales of fish, etc. The small opaque Coloured Discs (Nos. 31 to 36) also give good results in the Kaleidoscope.

3. Objects which are fairly flat, but which would be spoilt by being compressed between the two Glass slides as in picture A, can be given sufficient space by first putting a Rubber Band at each end of the lower slide before inserting the object. The top slide is then placed on top and the second pair of Rubber Bands placed in position as in A. The thickness of the two extra Rubber Bands encircling only one of the slides thus keeps the slides a trifle apart and imprisons without injuring such objects as small insects, minute moss plants, stamens of flowers and delicate objects generally.

4. Living objects may be put in a "Live-Box" as illustration B. This is made in a moment by sandwiching the Distance-ring (No. 8) between two of the Glass Slides (No. 23) and securing by means of two Rubber-bands (No. 37) as shown.

5. Pond water and liquid solutions generally may be placed in a miniature "aquarium" made in the same way as B. To make the Distance-ring water-tight, dip the lower rim in some melted wax or candle-grease before placing on the lower Glass slide.

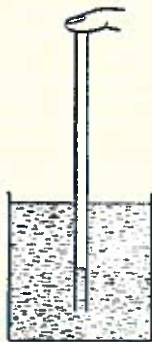

(C)

Note.—The small inhabitants of the pond may be captured as follows:—

- Press the forefinger on to the top end of the Glass Collecting Tube (No. 47), as shown in picture C.
- Keeping finger in position, push lower end of Tube into the water until it is exactly above the living object you desire to secure.
- Remove finger from top of tube, and you will find that the water rises upwards into the Tube, carrying with it your tiny "victim."
- Replace forefinger on top of Tube and lift out.
- Hold Tube over the centre of the Distance-ring which you have just affixed to the centre of the Glass Slide and remove the finger, when you will find that the water is released and the insect or other pond denizen is swimming about in a few drops of water.
- Cover with the second slide and secure with the two Rubber-bands as in picture B, when the subject is ready for examination.

## Hints on the Use of the Kaleidoscope.

Though the Kaleidoscope has always been well known as a toy and as an aid to Designers in the creation of patterns, it has never before been possible to make up from the same parts so many variations as are described in this book. Magnifying, Illuminated, Reflection, Micro, Projection and Photographic types may be constructed at will, and not the least interesting feature is that one may photograph and collect all kinds of Kaleidoscopic images in an Album.

Viewed through a Kaleidoscope any object or group of objects presents an entirely different pattern be it moved ever so slightly. The richest and most satisfying patterns are undoubtedly those produced by bright coloured objects such as petals of flowers, scraps of blotting paper stained with coloured inks, small coloured pictures, glass marbles, the Opaque Coloured Discs (Nos. 31 to 36, page 8), wools or threads, tinsel, etc.

For use with Lamp or Reflector illumination (see Models No. 63 to 68), semi-transparent coloured objects give beautiful results, such as scraps of coloured cellophane or celluloid, and the Transparent Discs (No. 27 to 30, page 8) can also be used to secure varied colour-illumination.

### USE OF A FOURTH MIRROR.

With the Hand Kaleidoscopes (Models No. 61, 62 and 69) interesting effects can be observed by grouping a number of small objects on one of the square Mirrors provided (No. 20, page 7) and then viewing them at close range. This little experiment provides a fourth reflecting surface, in addition to those of the three mirrors in the Kaleidoscope itself.

When using the Reflection Kaleidoscopes (Models No. 67 and 68) peer into the mirror at close range until you secure the best effect.

In all the Kaleidoscopes an effect of movement can be obtained by twisting the Optical Tube slowly round and round.

One of the most pleasing and effective objects for use, particularly in illuminated models of the Kaleidoscope, is furnished by sandwiching a variety of tiny clippings of coloured cellophane between two Glass Slides and securing by two Rubber Bands as in picture A on page 33. These scraps may be scattered haphazard over the entire surface of the glass, and by pushing the slide slowly to and fro under the Kaleidoscope, a very fascinating display of changing patterns may be viewed.

## General Hints on Camera and Projection Photography with Constructions

**PINHOLE CAMERAS.** Enough has been said in the descriptive matter under the various Models to indicate their scope for experimental use. By careful choice of subjects, trial exposures, etc., it is surprising how much can be achieved with what is usually regarded as only a toy.

**LENS CAMERAS (Box Type).** The fact of being able to "make" your own camera in a few moments and to place the lens in the right position according to the kind of picture you want to take affords, in itself, a great deal of interest. It is not pretended, of course, that results equal to those of moving-focus Cameras can be secured, but by making trial exposures, distances, etc., you can certainly secure pictures which would not seem possible with so simple an instrument. The Lens Stop (No. 44, page 10) or the large-pinhole disc (No. 45) should be used to give sharper definition. It will be found that in the majority of photographs secured the focus is clear enough in the centre of the picture, but not so good at the edges. A good plan, therefore, is to cut out a "mask" of black paper, leaving a suitable sized circle in the middle, so that you can put this over the negative before printing-out; thus getting a circular picture with white margins. This will be an inducement to you to concentrate the chief interest of the subjects chosen for photographing towards the middle of the plate, as professional photographers always do.

**FROSTED GLASS SCREEN.** The Frosted Glass Screen (No. 22), used for focussing the image before the photo is taken, should be rested on the ledges provided in the Optical Box, with its frosted surface towards the lens.

**USE OF CUT FILM OR PHOTOGRAPHIC PAPER.** When using cut film or photographic paper at the back of the Optical Box, be sure to "sandwich" it between the plain Glass Plate (No. 21, page 7) and the Frosted

Screen (No. 22, page 8) in order to keep it flat. When using photo paper with a glass negative for ordinary printing-out, either the Glass Plate or the Frosted Screen should also be placed over the back of the paper before replacing the Optical Box Lid prior to exposure.

**EXPOSURES.** Pending the introduction of standard grades of photographic plates, cut film and printing-out paper specially for use with Constructions, you should endeavour to find out roughly the times of exposure needed for the materials you are using. To do this without waste it is best to experiment with small pieces of cut film sandwiched in between the Glass Plate and Frosted Screen, as described above, giving various exposures, and marking the times on the backs after developing and fixing. Repeat this process with printing-out paper, and you will have a useful guide which will help you to avoid undue over or under-exposure in your future attempts. A good model to commence with is the Photo Copier and Enlarger (Model No. 47, page 24), with which you can use any clear object such as a small black-and-white picture, a miniature playing card, or a finger-print which you can impress on a small piece of white card by means of black shoe-polish. Add your signature below the finger-print in black ink, and you have an ideal subject for photography with this Model. Be careful to choose only the clearest red or black subjects for these trial exposures, and not newspaper photos or coloured pictures or objects.

## Hints on the Use of Microscopes.

**ILLUMINATION OF OBJECTS.** If the object is transparent, e.g., a fly's wing, it should be illuminated from below with either the Reflector (No. 42) or the Focus Electric Lamp (No. 24). Care should be taken to get the angle of the Reflector or the position of the Lamp exactly right, so that a good light is concentrated on the object to be viewed without glare. In the case of the Lamp it should be mounted as low as possible, and the best position found by moving it about.

If the object is opaque, it should be illuminated from the side or above, and it may be best, in some cases, to use a dark background. The black side of the Optical Box Lid (No. 2) may often be useful for this purpose.

**POND LIFE OR LIFE ON THE SEA-SHORE.** To secure samples of pond water or sea water from which to obtain your specimens, as described on page 33, select a pond which has plenty of green growth in it, or in the case of a pool by the sea-shore, first stir up the sand at the bottom of the pool. A useful collecting jar may be made by cutting a suitable sized hole in the bottom of a fishing net and passing the mouth of a wide-mouthed bottle or jar through the hole. Tie the net round the neck of the jar securely and dip for suitable samples till you obtain one that has plenty of small inhabitants whose movements can be seen.

Endless fascinating hours may be spent in observing these tiny creatures and organisms, especially through the High Power Compound Microscope (Model No. 25) and the High Power Projection Microscope (Model No. 56) in the latter of which you will be able to see the pond life in active movement projected on to the Frosted Glass Screen at the top of the Optical Box.

Scouts and Hikers can also collect abundant material on their field days or rambles, not only from the water, but also from the land.

**DARK-GROUND ILLUMINATION.** At one time "dark-ground illumination" was used very extensively, but today it is not common practice. It is usually well worth while to employ both light and dark ground illumination, especially with the medium power microscope.

**"HOME-MADE" OBJECTS.** Under the descriptions of the various Models, many suitable objects have already been referred to, such as parts of insects, a human hair, a few grains of pollen, of salt, sugar, starch, etc. Only a very small quantity of material is required, especially when using a Compound Microscope. These may be placed in the centre of a slide or sandwiched between two slides, as illustrated on page 33.

Other interesting objects are provided by paring-off an extremely thin slice of potato, onion, carrot, etc. Use a very sharp knife, or safety-razor blade and do not take a piece more than a tenth of an inch long, and as thin as you can possibly cut it. Place the sections in a saucer of water as soon as you have cut them and transfer the smallest and thinnest to the centre of a slide with the point of a needle.

**CRYSTALS.** Endless instruction and interest can be enjoyed by the study of crystals of cheap and common substances such as salt, hypo, sal ammoniac, Epsom or Glauber's salts, etc. Place a quantity in two to three parts of water, and when it is dissolved, transfer a few drops to the centre of a slide by means of the Collecting Tube, as illustrated on page 33—taking care that the tube is quite clean and that the slide is free from dust. Now cover the slide with a cardboard box, box lid or other convenient protector to keep away dust, and leave it overnight or for a period of hours until the moisture is all evaporated. Do not jar or shake the slide during the process of crystallisation, and you will be rewarded by seeing not only how the crystals group themselves, but how they differ in their individual forms. Crystals are best observed through the Medium Power Microscopes by bright or by dark ground illumination.

## Hints on the Use of Midget and Button-Hole-Picture Cameras.

In the form presented by Constructions these fascinating little Midget-type Cameras afford an entirely new field for experiments.

A few moments study of the Models Illustrated on pages 22 to 24 will show the principles of their construction, and how to focus the diminished image of the photographic subject on to the Frosted Disc (No. 26) inserted into the rear Ring-mount.

First find out the distance which gives the clearest image on the Frosted-Disc and the exact position of the camera which brings this image into the centre of the Frosted-Disc. Mark this spot. Then in a dark room cut out a circular piece of photo film with scissors, using a half-penny as a guide, and insert into the rear Ring-mount in place of the Frosted-Disc. Secure with a split-ring. To exclude the light from the back of this circle of film insert a half-penny into the Tubular-mount Cap, as in Fitment No. 2, and secure firmly with another split-ring, taking care to press the Split-ring well down and flush all round with the circumference of the half-penny. Now replace the Tubular-mount Cap on to the Tubular-mount; place the Camera Cap on to the front Ring-mount, and your little camera is ready for use.

Place it on the exact spot you have already marked, remove the Camera Cap for the necessary time to make the exposure, replace, and then develop and fix your small disc film in the usual way, when you will have a picture of the required size, ranging from  $\frac{1}{4}$ th to  $\frac{1}{8}$ th of an inch wide in the case of the Micro-reducing Cameras to one of about  $\frac{3}{4}$  of an inch wide in the case of the Button-Hole-Picture Cameras.

See Note on *Photographic Exposures*, page 34.

## The New "Craze." Collecting Finger-Prints in Your Own "Scotland-Yard" Albums.

Finger- and thumb-prints impressed on a glass slide or piece of white card and afterwards photographed for inclusion in a "Scotland Yard" Album afford a fascinating new pastime for collectors, especially if each impress is accompanied by a signature in good black ink. It will be found that even amongst members of the same family the differences in the finger-prints are most marked. Imprints may be made on glass slides or plates with the aid of grease-paint or face powder and placed against a dark background for viewing through a Magnifier or photographing. Rubbing the finger or thumb on a piece of coal, or lightly pressing in a tin of black boot-polish and then taking the impress on a piece of white card or paper or on glass, will also be effective. Not only can finger-prints be enlarged by using the Photo Copier and Enlarger (Model No. 47), but they may be taken direct on to photographic paper without the use of a photoplate, giving a particularly clear picture of the subject. Finger-prints on a glass slide may also be projected on to a wall or screen, as, for instance, by the Magic Lantern (Model No. 51) or on the Frosted-glass Screen (No. 22), as in the Projectors (Models No. 52 and 53).

Send in your Name and Address for  
advance particulars of the New  
"Monthly Science" Magazine.

# THE CONSTRUMAG

The Official Journal of Construments  
6d. Monthly

**T**HIS Magazine will present, each month, many new and interesting uses of Construments Models; will keep you informed of all new developments, new experiments, and a thousand-and-one things which are arising out of this unique "Hobby of Ten Thousand Thrills."

Never before has a magazine like this been published. It is coming in an age when everybody, young and old alike, is keener on scientific subjects and scientific knowledge than ever before in history.

Popular, bright, educative, informative, and profusely illustrated, the "Construmag" will be hailed with delight by every Boy and Girl of suitable age, and will also come as a boon to Educational Authorities and a means of extending and improving our national system of scientific education.

Send in your name and address and full particulars will  
be posted to you as soon as possible

Magazine Dept.  
Construments Ltd., 18 Gray's Inn Road, London, W.C.1